

Engineering & Piping Design Guide

Fiber Glass Systems Fiberglass Reinforced Piping Systems

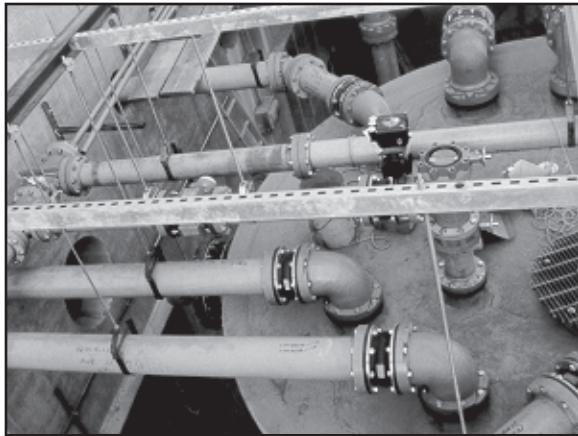

NOV Fiber Glass Systems™

INTRODUCTION

INTRODUCTION

Fiber Glass Systems' (FGS) fiberglass reinforced epoxy and vinyl ester resin piping systems possess excellent corrosion resistance and a combination of mechanical and physical properties that offer many advantages over traditional piping systems. Fiber Glass Systems is recognized worldwide as a leading supplier of piping systems for a wide range of chemical and industrial applications.

This manual is provided as a reference resource for some of the specific properties of FGS piping systems. It is not intended to be a substitute for sound engineering practices as normally employed by professional design engineers.

Fiber Glass Systems has an international network of distributors and trained field personnel to advise on proper installation techniques. It is recommended they be consulted for assistance when installing FGS piping systems. This not only enhances the integrity of the piping system, but also increases the efficiency and economy of the installation.

Additional information regarding installation techniques is provided in the following FGS installation manuals:

Manual No. F6000 *Pipe Installation Handbook
for Tapered Bell & Spigot Joints*

Manual No. F6080 *Pipe Installation Handbook
for Straight Socket Joints and
Butt & Wrap Joints*

Manual No. F6300 *Pipe Installation Handbook
for Marine-Offshore Piping*

GENERAL POLICY STATEMENT

It is the policy of Fiber Glass Systems to improve its products continually. In accordance with that policy, the right is reserved to make changes in specifications, descriptions, and illustrative material contained in this manual as conditions warrant. Always cross-reference the bulletin date with the most current version listed at www.smithfibercast.com. The information contained herein is general in nature and is not intended to express any warranty of any type whatsoever nor shall any be implied. In providing this technical information, Fiber Glass Systems has not been retained as and does not assume the role of engineering consultant to any user or customer. Fiber Glass Systems does not accept and specifically disclaims any responsibility or warranty for the design, specification, installation, or design performance of any fiberglass piping system.



SAFETY

This safety alert symbol indicates an important safety message. When you see this symbol, be alert to the possibility of personal injury.

PIPING SYSTEMS

Epoxy Resin Systems:

- Z-CORE® (High Performance Resin)
- CENTRICAST PLUS® RB-2530
 - CENTRICAST® RB-1520
- GREEN THREAD®
 - GREEN THREAD *Performance Plus*
- MARINE-OFFSHORE
 - GREEN THREAD 175
 - GREEN THREAD 175 Conductive
 - GREEN THREAD 250
 - GREEN THREAD 250 Cconductive
 - GREEN THREAD 250 Fire Resistant
- RED THREAD® II
 - RED THREAD II *Performance Plus*
 - RED THREAD II JP
- SILVER STREAK® (FGD Piping)
- CERAM CORE® (Ceramic-lined Piping)
- F-CHEM® (Custom Piping)
- HIGH PRESSURE Line Pipe and Downhole Tubing*

Vinyl Ester Systems:

- CENTRICAST PLUS CL-2030
 - CENTRICAST CL-1520
- F-CHEM (Custom Piping)

* Available from FIBER GLASS SYSTEMS, National Oilwell Varco Company, San Antonio, Texas
Phone: (210) 434-5043 · FAX: (210) 434-7543
Website: <http://www.starfiberglass.com>

Fiber Glass Systems has developed a computer program specifically for our fiberglass products. This software program called *Success By Design* is available on our website at <http://www.smithfibercast.com>.

© 2005, National Oilwell Varco
© Trademarks of Varco I/P, Inc.

TABLE OF CONTENTS

<p>Introduction..... i</p> <p>Piping System Selection..... 1</p> <p>SECTION 1 — Flow Properties2</p> <p>Preliminary Pipe Sizing.....2</p> <p>Detailed Pipe Sizing</p> <p style="padding-left: 20px;">A. Liquid Flow.....2</p> <p style="padding-left: 20px;">B. Loss in Pipe Fittings.....4</p> <p style="padding-left: 20px;">C. Open Channel Flow5</p> <p style="padding-left: 20px;">D. Gas Flow.....5</p> <p>SECTION 2 — Above Ground System Design Using Supports, Anchors & Guides.....7</p> <p>Piping Support Design</p> <p style="padding-left: 20px;">A. Support Bracket Design.....7</p> <p style="padding-left: 20px;">B. Typical Guide Design.....8</p> <p style="padding-left: 20px;">C. Anchor Design9</p> <p style="padding-left: 20px;">D. Piping Support Span Design.....11</p> <p>SECTION 3 — Temperature Effects.....12</p> <p>System Design12</p> <p>Thermal Properties and Characteristics12</p> <p>Fundamental Thermal Analysis Formulas</p> <p style="padding-left: 20px;">A. Thermal Expansion and Contraction.....13</p> <p style="padding-left: 20px;">B. Anchor Restraint Load13</p> <p style="padding-left: 20px;">C. Guide Spacing13</p> <p>Flexibility Analysis and Design</p> <p style="padding-left: 20px;">A. Directional Change Design13</p> <p style="padding-left: 20px;">B. Expansion Loop Design14</p> <p style="padding-left: 20px;">C. Expansion Joint Design14</p> <p style="padding-left: 20px;">D. Heat Tracing15</p> <p style="padding-left: 20px;">E. Thermal Conductivity16</p> <p style="padding-left: 20px;">F. Thermal Expansion in Buried Pipe.....16</p> <p style="padding-left: 20px;">G. Pipe Torque due to Thermal Expansion16</p> <p>SECTION 4 — Pipe Burial17</p> <p>Pipe Flexibility.....17</p> <p>Burial Analysis</p> <p style="padding-left: 20px;">A. Soil Types17</p> <p style="padding-left: 20px;">B. Soil Modulus18</p> <p>Trench Excavation and Preparation</p> <p style="padding-left: 20px;">A. Trench Size.....18</p> <p style="padding-left: 20px;">B. Trench Construction.....18</p> <p style="padding-left: 20px;">C. Maximum Burial Depth.....19</p> <p style="padding-left: 20px;">D. Roadway Crossing.....19</p> <p>Bedding and Backfill</p> <p style="padding-left: 20px;">A. Trench Bottom20</p> <p style="padding-left: 20px;">B. Backfill Materials20</p> <p style="padding-left: 20px;">C. Backfill Cover.....20</p> <p style="padding-left: 20px;">D. High Water Table.....20</p>	<p>SECTION 5 — Other Considerations21</p> <p style="padding-left: 20px;">A. Abrasive Fluids21</p> <p style="padding-left: 20px;">B. Low Temperature Applications21</p> <p style="padding-left: 20px;">C. Pipe Passing Through Walls or Concrete Structures.....21</p> <p style="padding-left: 20px;">D. Pipe Bending21</p> <p style="padding-left: 20px;">E. Static Electricity22</p> <p style="padding-left: 20px;">F. Steam Cleaning22</p> <p style="padding-left: 20px;">G. Thrust Blocks.....22</p> <p style="padding-left: 20px;">H. Vacuum Service.....22</p> <p style="padding-left: 20px;">I. Valves22</p> <p style="padding-left: 20px;">J. Vibration.....23</p> <p style="padding-left: 20px;">K. Fluid (Water) Hammer23</p> <p style="padding-left: 20px;">L. Ultraviolet (U.V.) Radiation and Weathering.....23</p> <p style="padding-left: 20px;">M. Fungal, Bacterial, and Rodent Resistance23</p> <p>SECTION 6 — Specifications and Approvals24</p> <p style="padding-left: 20px;">A. Compliance with National Specifications24</p> <p style="padding-left: 20px;">B. Approvals, Listings, and Compliance with Regulations24</p> <p style="text-align: center;">APPENDICES</p> <p>Appendix A Useful Formulas27</p> <p>Appendix B Conversions.....30</p> <p style="text-align: center;">LIST OF TABLES</p> <p>Table 1.0 Typical Applications 1</p> <p>Table 1.1 Flow Resistance K Values for Fittings..... 4</p> <p>Table 1.2 Typical Liquid Properties..... 4</p> <p>Table 1.3 Typical Gas Properties.....6</p> <p>Table 2.0 Minimum Support Width..... 7</p> <p>Table 2.1 Saddle Length 8</p> <p>Table 4.0 Recommended Bedding and Backfill 18</p> <p>Table 4.1 Nominal Trench Widths..... 18</p> <p>Table 6.0 ASTM 2310 Classification24</p> <p>Table 6.1 Classifying Fiberglass Flanges to ASTM D4024.....25</p> <p>Table 6.2 Classifying Fiberglass Pipe Using ASTM D2310 and Specifying Pipe Using ASTM D2996 and D2997.....26</p>
---	--

PRODUCT SELECTION and APPLICATION

PRODUCT SYSTEM SELECTION

When selecting a piping system for a particular application, it is important to consider the corrosive characteristics of the media to which the pipe and fittings will be exposed, the normal and potential upset temperatures and pressures of the system, as well as other environmental factors associated with the project. Fiberglass reinforced plastic (FRP) piping systems provide excellent corrosion resistance, combined with high temperature and pressure capabilities, all at a relatively low installed cost. Fiber Glass Systems engineers, using epoxy, vinyl ester, and polyester resins, have developed a comprehensive array of piping systems designed to meet the most demanding application requirements. Piping systems are available with liners of varying type and thickness, with molded, fabricated, or filament wound fittings, ranging in size from 1" to 72" (25 to 1800 mm) in diameter.

TYPICAL APPLICATIONS

Fiberglass piping is used in most industries requiring corrosion resistant pipe. FRP piping is used in vent and liquid applications that operate from -70°F to 300°F (-57°C to 149°C). Fiber Glass Systems piping systems use high grade resins that are resistant to acids, caustics or solvents. Abrasion resistant materials can be used in the piping inner surface liner to enhance wear resistance to slurries. Table 1.0 is a brief list of the many applications and industries where fiberglass piping has been used successfully. See FGS Bulletin No. E5615 for a complete chemical resistance guide.

Fiber Glass Systems piping systems can be installed in accordance with the ASME B 31.3 piping code. Second party listings from regulatory authorities such as Factory Mutual, NSF, UL/ULC, and marine registrars are in place on several of these piping systems.

TABLE 1.0 Typical Fiberglass Pipe Applications by Industry

Applications	INDUSTRY								
	Chemical Process	Petro Chemical	Marine Offshore	Pharmaceutical	Food Processing	Power Plants	Pulp and Paper	Waste Water Treatment	Mining and Metal Refining
Aeration								X	
Brine Slurry	X								
Bottom Ash						X			
Chemical Feed	X	X			X	X	X	X	X
Column Piping			X						
Condensate Return	X	X	X	X	X	X	X		
Conduit		X			X	X	X		
Cooling Water	X	X		X	X	X			
Disposal Wells	X	X	X					X	X
Downhole Tubing & Casing		X	X					X	
Effluent Drains	X	X	X	X	X	X	X	X	X
Fire Mains		X	X			X	X		X
Flue Gas Desulfurization						X			
Guttering & Downspouts	X				X	X	X		
Oily Water		X	X						X
Scrubber Headers	X	X				X			
Seawater		X	X			X			
Slurry	X					X			
Vents	X	X	X	X	X		X	X	X
Water	X	X	X	X	X	X	X		X
Waste Treatment	X		X	X	X	X	X	X	X
Buried Gasoline		X							

SECTION 1. Flow Properties

The smooth interior surface of fiberglass pipe, combined with inside diameters larger than steel or thermoplastic pipe of the same nominal diameter, yield significant flow advantages. This section provides design techniques for exploiting the flow capacity of fiberglass pipe.

PRELIMINARY PIPE SIZING

The determination of the pipe size required to transport a given amount of fluid is the first step in designing a piping system.

Minimum recommended pipe diameters.

Clear Liquids

$$\text{Eq. 1} \quad d := \frac{0.73 \cdot \sqrt{\frac{Q}{S_g}}}{\rho^{0.33}}$$

Corrosive or erosive fluids

$$\text{Eq. 2} \quad d := \frac{1.03 \cdot \sqrt{\frac{Q}{S_g}}}{\rho^{0.33}}$$

Where:

d = Pipe inner diameter, inch

Q = Flow rate, gal/min (gpm)

S_g = Fluid specific gravity, dimensionless

ρ = Fluid density, lb/ft³

Recommended maximum fluid velocities

Clear fluids

$$\text{Eq. 3} \quad V := \frac{48}{\rho^{0.33}}$$

Corrosive or erosive fluids

$$\text{Eq. 4} \quad V := \frac{24}{\rho^{0.33}}$$

Where:

V = velocity, ft/sec

ρ = fluid density, lb/ft³

Typical fiberglass piping systems are operated at flow velocities between 3 & 12 ft/sec.

DETAILED PIPE SIZING

A. Liquid Flow

Fluid flow characteristics are very sensitive to the absolute roughness of the pipe inner surface. The absolute roughness of Smith Fibercast piping is (0.00021 inches) 1.7×10^{-5} feet⁽¹⁾. This is less than 1/8 the average value for (non-corroded) new steel of (0.0018 inch) 15×10^{-5} feet⁽²⁾. For ambient temperature water, the equivalent Manning value (n) is 0.009 and the Hazen-Williams coefficient is 150.

The most commonly used pipe head loss formula is the Darcy-Weisbach equation.

$$\text{Eq. 5} \quad H_f := f \cdot \frac{L}{D} \cdot \frac{V^2}{2g}$$

Where:

H_f = Pipe friction loss, ft(m)

f = Friction factor

L = Length of pipe run, ft (m)

D = Inner diameter, ft (m)

V = Fluid velocity, ft/sec (m/sec)

g = Acceleration of gravity, 32.2 ft/s² (9.81 m/s²)

The friction factor is dependent on the flow conditions, pipe diameter and pipe smoothness. The flow conditions are determined by the value of the Reynolds Number. There are four flow zones defined by the Reynolds Number; they are laminar, critical, transitional and turbulent.

For laminar flow (Reynolds Number below 2,000), the friction factor is calculated by Eq. 6

$$\text{Eq. 6} \quad f := \frac{64}{Nr}$$

Where Nr is the dimensionless Reynolds Number

$$\text{Eq. 7} \quad Nr := \frac{D \cdot V}{\nu}$$

Where:

D = Pipe inner diameter, ft (m)

V = Fluid velocity, ft/sec (m/sec)

ν = Fluid kinematic viscosity, ft²/sec (m²/sec)

Nr = Reynolds Number

f = Friction Factor

¹ Based on testing at Oklahoma State University in Stillwater, OK.

² Cameron Hydraulic Data, Ingersoll-Rand, Seventeenth Edition, 1988.

SECTION 1. FLOW PROPERTIES

For turbulent flow (Reynolds Number greater than 4,000), the friction factor is calculated by the Colebrook Equation.

$$\text{Eq. 8} \quad \frac{1}{\sqrt{f}} := -2 \cdot \log \left(\frac{e}{3.7 \cdot D} + \frac{2.51}{\text{Nr} \cdot \sqrt{f}} \right)$$

Where:

D = Pipe inner diameter, inch (mm)

e = Absolute roughness, inch (mm)

Nr = Reynolds Number, unit less

f = Friction Factor, unit less

The flow with Reynolds numbers between 2,000 and

4,000 is considered the critical zone. Flow is neither fully laminar or turbulent, although it is often assumed to be laminar for calculation purposes. Flow with Reynolds numbers between 4,000 and 10,000 is called the transitional zone where use of the Colebrook equation is considered more appropriate.

These equations are quickly solved using a computer program, *Success By Design*, developed by Smith Fibercast specifically for our fiberglass products.

A demonstration of the Darcy-Weisbach and Colebrook equations for fiberglass pipe is shown in Figure 1.0.

Figure 1.0 **Fiberglass Pipe Pressure Loss Curves for Water**
Basis: Specific Gravity of 1.0 and Viscosity of 1.0 cps

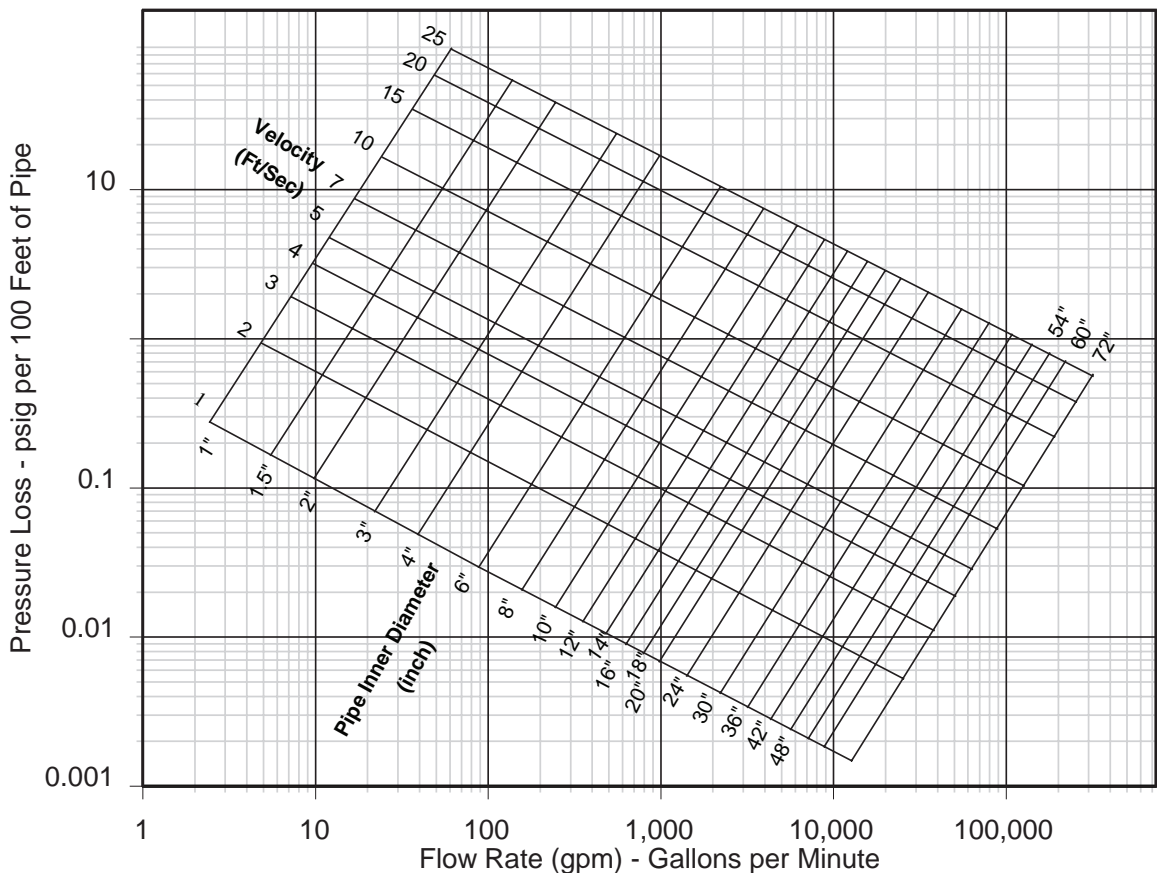

SECTION 1. FLOW PROPERTIES

B. Loss in Pipe Fittings

The head loss through a fitting is proportional to the fluid velocity squared (V^2). Equation 9 relates the head loss in fittings to the fluid velocity by incorporating a fitting loss factor obtained from experimental test data.

$$\text{Eq. 9} \quad h_f := \frac{k \cdot V^2}{2 \cdot g}$$

Where:

h_f = Fitting friction loss, ft (m)

k = Flow resistance coefficient

V = fluid velocity, ft/sec

g = acceleration of gravity, 32.2 ft/s²

Typical values of k are given in Table 1.1.

The most common method for determining the contribution to the overall piping system of the fittings head loss is to convert the fitting head loss into an equivalent pipe length. As an example, use 60°F water as the working fluid in a 3-inch diameter piping system with an internal flow of 10 ft/sec. The equivalent pipe length for a short radius 90° elbow would be 6.9 feet for RED THREAD II and 5.9 feet for CENTRICAST PLUS CL-2030. The two piping systems have different inner diameters that contribute to the differences in equivalent footage. Therefore for best accuracy it is recommended that FGS computer software *Success By Design* be used to determine fittings equivalent piping footage.

Typical liquid properties are presented in Table 1.2.

TABLE 1.1 Flow Resistance k Values for Fittings

Fitting/Size (In.)	1	1 1/2	2	3	4	6	8-10	12-16	18-24
Short Radius 90° Elbow	0.75	0.66	0.57	0.54	0.51	0.45	0.42	0.39	0.36
Sweep Radius 90° Elbow	0.37	0.34	0.30	0.29	0.27	0.24	0.22	0.21	0.19
Short Radius 45° Elbow	0.37	0.34	0.30	0.29	0.27	0.24	0.22	0.21	0.19
Sweep Radius 45° Elbow	0.20	0.18	0.16	0.15	0.14	0.13	0.12	0.11	0.10
Tee Side Run	1.38	1.26	1.14	1.08	1.02	0.90	0.84	0.78	0.72
Tee Thru Branch	0.46	0.42	0.38	0.36	0.34	0.30	0.28	0.26	0.24

TABLE 1.2 Typical Liquid Properties

Type of Liquid	Specific Gravity Sg at 60°F	Viscosity at 60°F Centipose
10% Salt Water	1.07	1.40
Brine, 25% NaCl	1.19	2.20
Brine, 25% CaCl ₂	1.23	2.45
30° API Crude Oil	0.87	13.00
Average Fuel Oils	0.93	8.90
Kerosene	0.83	1.82
Auto Gasoline	0.72	1.20
Aviation Gasoline	0.70	0.46
50% Sodium Hydroxide (NaOH)	1.53	95.00
<i>Mil 5624 Jet Fuels:</i>		
JP3	0.75	0.79
JP5	0.84	2.14
JP8	0.80	1.40
<i>Acids:</i>	<i>At 68°F</i>	<i>At 68°F</i>
60% Sulfuric (H ₂ SO ₄)	1.50	6.40
98% Sulfuric (H ₂ SO ₄)	1.83	24.50
85% Phosphoric (H ₂ PO ₄)	1.69	12.00
37.5% Hydrochloric (HCl)	1.46	1.94

SECTION 1. FLOW PROPERTIES

C. Open Channel Flow

One of the most widely used, formulas for open-channel flow is that of Robert Manning. This formula in Equation 10 is useful in predicting the flow in open "gravity feed" fiberglass sewer lines. FGS software *Success By Design* is recommended to perform these calculations.

$$\text{Eq. 10} \quad Q := \frac{k}{n} \cdot A \cdot Rh^{\frac{2}{3}} \cdot S^{0.5}$$

Where:

Q = Flow rate in ft³/sec (m³/sec)

A = Flow cross sectional area, ft² (m²)

Rh = Wetted perimeter, ft (m)

S = Hydraulic slope, dimensionless

S = H/L

H = elevation change over the pipe length
"L", ft (m)

L = Length measured along the pipe, ft (m)

k = 1.49 (US Customary units, ft. & sec.)

k = 1.0 for flow in m³/sec. Use meter for A, Rh, & D.

n = 0.009 Manning's constant for fiberglass

$$\text{Eq. 11} \quad Rh := \frac{D}{4} \left(1 - \frac{\sin(2\theta)}{2\theta} \right)$$

Where:

D = Pipe inner diameter, ft (m)

U = Wet contact angle, radians

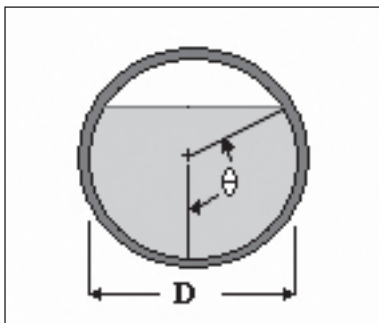

D. Gas Flow

Fiber Glass Systems piping systems can be used in pressurized gas service when the pipe is buried at least three feet deep.



In above ground applications, they can be used provided the pressure does not exceed the values shown below and further that the pipe is properly safeguarded when conveying a hazardous gas.

Pipe Diameter	1"	1½"	2"	3"	4"	6"	8"	10"	12"	14"	16"
psig	25	25	25	25	25	25	14	9	6	5	4

Consult your local Smith Fibercast representative for safeguard procedures.

Since the inside diameter of Fiber Glass Systems pipe is smoother and larger than steel pipe of corresponding nominal diameters, less frictional resistance is developed under turbulent flow conditions, resulting in greater flow capacities. There are two basic equations used to calculate pressure loss for flow of gases. To determine which equation is required, the transition flow rate must be determined from Equations 12, 13 and 14. If the desired flow rate is greater than the value calculated from equation 14, then the equations for fully turbulent or rough pipe flow must be used. If the desired flow rate is less than the value calculated from equation 14, then the equation for partially turbulent or smooth pipe flow must be used.

Equations for transition flow rate:

$$\text{Eq. 12} \quad KT := \left(\frac{0.4692 \cdot T_b}{P_b \cdot \sqrt{G \cdot T \cdot Z}} \right)^2$$

$$\text{Eq. 13} \quad KS := \left(\frac{0.6643 \cdot T_b}{P_b \cdot T^{0.5556} \cdot Z^{0.5556} \cdot G^{0.4444} \cdot \mu^{0.1111}} \right)^{1.8}$$

$$\text{Eq. 14} \quad QT := \left(\frac{KT}{KS} \right)^5 \cdot D \cdot \left(\log \left(\frac{3.7 \cdot D}{K} \right) \right)^{10}$$

Where QT = Transition Flow Rate

$$\text{Eq. 15} \quad Q := \frac{0.4692 \cdot T_b}{P_b} \cdot \left[\frac{\left[(P_i)^2 - (P_o)^2 \right] \cdot D^5}{G \cdot T \cdot Z \cdot L} \right]^{0.5} \cdot \log \left(\frac{3.7 \cdot D}{K} \right)$$

(1) IGT Distribution Equations from American Gas Association Plastic Pipe Handbook for Gas Service.

For fully turbulent or rough pipe flow:⁽¹⁾

or

$$\text{Eq. 16 } P_o := \left[(P_i)^2 - \left[\frac{G \cdot T \cdot Z \cdot L}{D^5} \cdot \left(\frac{Q \cdot P_b}{0.4692 \cdot T_b \cdot \log\left(\frac{3.7 \cdot D}{K}\right)} \right)^2 \right] \right]^{0.5}$$

For partially turbulent or smooth pipe flow:⁽¹⁾

or

$$\text{Eq. 17 } Q := \frac{0.6643 \cdot T_b}{P_b} \cdot \left[\frac{(P_i)^2 - (P_o)^2}{T \cdot Z \cdot L} \right]^{0.5556} \cdot \frac{D^{2.6667}}{G^{0.4444} \cdot \mu^{0.1111}}$$

Where:

$$\text{Eq. 18 } P_o := \left[(P_i)^2 - L \cdot T \cdot Z \cdot \left(\frac{Q \cdot P_b \cdot G^{0.444} \cdot \mu^{0.1111}}{0.6643 \cdot T_b \cdot D^{2.6667}} \right)^{1.8} \right]^{0.5}$$

- D = Inside Diameter (in.)
- G = Specific Gravity (S.G. of air = 1.0)
- L = Length of Pipe Section (ft.)
- P_b = Base Pressure (psia)
- P_i = Inlet Pressure (psia)
- P_o = Outlet Pressure (psia)
- Q = Flow Rate (MSCFH - thousand standard cubic ft. per hr.)
- T_b = Base Temperature (°R)
- T = Temperature of Gas (°R)
- Z = Compressibility Factor
- m = Viscosity (lb./ft. sec.)
- K = Absolute Roughness of Pipe =
0.00021 (in.) for Fiber Glass Systems pipe
- °R = °F + 460°
- m = (lb./ft. sec.) = m (centipoise) ÷ 1488
- psia (Absolute) = psig (Gauge) + 14.7

FGS can perform computer calculations using the *Success By Design* program to solve gas flow problems for: pipe size, Q, P_i, or P_o if the other variables are known.

TABLE 1.3 Typical Gas Properties

Type of Gas	Specific Gravity at 60°F ⁽¹⁾	Viscosity at 60°F lb./ft. sec.
Air	1.02	.0000120
Carbon Dioxide	1.56	.0000098
Carbon Monoxide	.99	.0000116
Chlorine	2.51	.0000087
Ethane	1.06	.0000060
Methane	.57	.0000071
Natural Gas	.64	.0000071
Nitrogen	.99	.0000116
Nitrous Oxide	1.56	.0000096
Oxygen	1.13	.0000132
Sulfur Dioxide	2.27	.0000083

(1) All Specific Gravity based on air = 1.0 at 70° F.

SECTION 2. SUPPORTS, ANCHORS and GUIDES

SECTION 2. Above Ground System Design - Supports, Anchors and Guides

PIPING SUPPORT DESIGN

Above ground piping systems may be designed as restrained or unrestrained. Selection of the design method is dependent on variables such as operating temperature, flow rates, pressures and piping layout. System designs combining the two methods often lead to the most structurally efficient and economical piping layout.

Unrestrained System Design

The unrestrained system is often referred to as a "simple supported" design. It makes use of the inherent flexibility of fiberglass pipe to safely absorb deflections and bending stresses. Simple pipe hangers or steel beams are used to provide vertical support to the pipe. These simple supports allow the piping system to expand and contract freely resulting in small axial stresses in the piping system. Long straight runs often employ changes-in-direction to safely absorb movement due to thermal expansion and contractions, flow rate changes, and internal pressure.

Experience has shown the use of too many simple pipe hangers in succession can result in an unstable line when control valves operate and during pump start-up and shut-down. To avoid this condition the designer should incorporate guides periodically in the line to add lateral stability. In most cases, the placement of lateral guides at intervals of every second or third support location will provide adequate stability. Axial stability in long pipe runs may be improved by the proper placement of a "Pipe Hanger with Axial Guide" as shown in Figure 2.6. The project piping engineer must determine the guide requirements for system stability.

Restrained System Design

The restrained system is often referred to as an "anchored and guided design". The low modulus of elasticity for fiberglass piping translates to significantly smaller thermal forces when compared to steel. Anchors are employed to restrain axial movement and provide vertical support in horizontal pipelines. Anchors used to restrain thermal expansion create compressive forces in the pipeline. These forces must be controlled by the use of pipe guides to prevent the pipe from buckling. In cases where axial loads created by anchoring a pipe run are excessively high, the use of expansion loops or expansion joints must be employed. When using anchors, the effect of system contraction should be considered. See the thermal analysis section for more thorough information on handling thermal loads.

FIBERGLASS PIPING SYSTEM "SUPPORT" TERMINOLOGY

Fiberglass piping engineers use three basic structural components to install a piping system. They are the support, anchor, and guide.

Support

Pipe supports hold the pipe in position and when properly spaced prevent excessive deflections due to the weight of the pipe, fluid, external insulation and other loads.

Anchor

Pipe anchors restrain the pipe against axial movement or applied forces. These forces may result from thermal loads, water hammer, vibrating equipment, or externally applied mechanical loads.

Guide

Pipe guides prevent lateral (side-to-side) movement of the pipe. Guides are required to prevent the pipe from buckling under compressive loading. For example: When anchors are used to control thermal expansion, guides are always required.

A. Support Bracket Design

The hanger supports in Figure 2.0 must have sufficient contact areas to distribute the load. The preferred circumferential contact is 180°. Refer to Table 2.0 for minimum width requirements. When less than 180° of circumference contact and/or larger diameters are encountered, support saddles as shown in Figure 2.1 should be used.

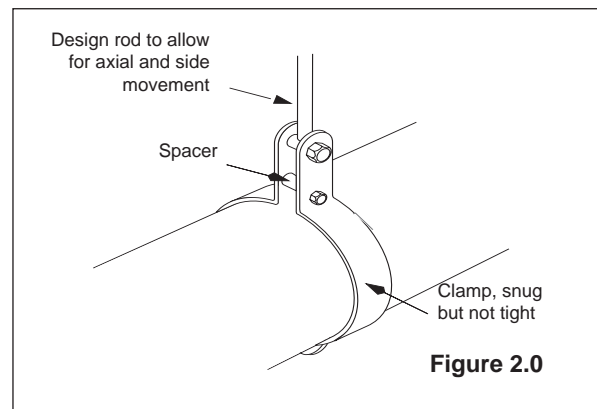

Note: Valid for $S_g < 1.25$

TABLE 2.0 Minimum Support Width

Pipe Size (In.)	Class I (In.)	Class II (In.)
1	$\frac{7}{8}$	$\frac{7}{8}$
1½	$\frac{7}{8}$	$\frac{7}{8}$
2	$\frac{7}{8}$	$\frac{7}{8}$
3	1¼	1¼
4	1¼	1¼
6	1½	1½
8	1¾	1¾
10	1¾	2⅝
12	2	3¼
14	2	4

SECTION 2. SUPPORTS, ANCHORS and GUIDES

Class I Products: CENTRICAST PLUS CL-2030, CENTRICAST PLUS RB-2530, CHEM THREAD, Z-CORE. Minimum required contact angle is 110°

Class II Products: RED THREAD II, GREEN THREAD, SILVER STREAK, F-CHEM, CENTRICAST CL-1520, CENTRICAST RB-1520. Minimum required contact angle is 170°

Class III Products: GREEN THREAD 175/250 Marine Offshore Products. Information is available in Bulletin C3850.

For sizes 16-24 inch, the support bracket bearing stress should not exceed 50 lb/in². The use of support saddles with these pipe sizes is recommended. Refer to Figure 2.1.

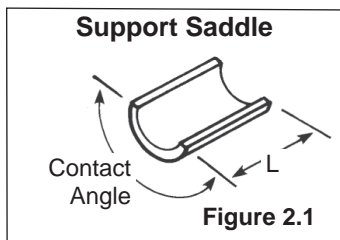

Class 1 contact angle = 110°-120°.

TABLE 2.1 Saddle Length

Pipe Size (In.)	Class I (In.)	Class II (In.)
1	3	2
1½	3	2
2	4	4
3	4	4
4	4	4
6	4	6
8	5 5/8	8
10	8 3/8	10
12	8 3/8	12
14	8 3/8	14
16-24	-	(1)(2)

1. Use the pipe diameter as minimum saddle length.
2. Refer to F-CHEM product bulletin for sizes greater than 24-inch diameter.

Typical applications using support saddles are shown in Figures 2.2 & 2.3. The support saddles should be bonded to the pipe wall.

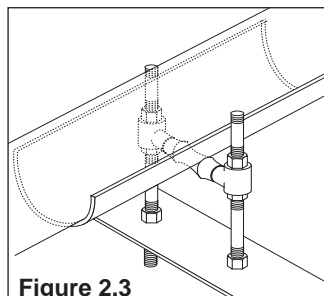
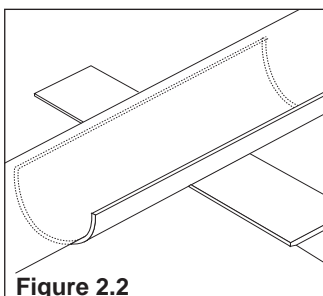

The substructure design should include the static weight of the pipe, fluid and any external loads such as insulation, wind, ice, snow, and seismic.

Guide Design

B. Typical Guide Usage

1. Between anchors to prevent buckling of pipeline at elevated temperatures.
2. Near entry points of expansion joints and loops to ensure proper functionality.
3. To provide system stability.

Properly designed and installed guides prevent the pipe from sliding off support beams and allow the pipe to freely move in the axial direction. Guides should be used with 180° support saddles to reduce wear and abrasion of the pipe walls.

Figure 2.4 shows a common method of guiding fiberglass pipe. A clearance of 1/16- to 1/8-inch is recommended between the guide and the wear saddle. A 180° support “wear” saddle is recommended to prevent point contact between the bolt and pipe wall. The U-bolt should not be tightened down onto the pipe. It should be tightened to the structural support member using two nuts and appropriate washers. Clearance is recommended between the U-bolt and the top of the pipe.

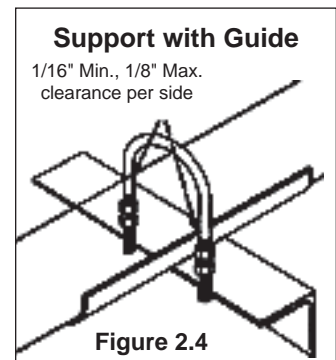

Eight-inch diameter and larger pipe are generally allowed more clearance than smaller sizes. The determination of acceptable clearance for these sizes is dependent on the piping system and should be determined by the project piping engineer.

Another design practice is to use U-straps made from flat rolled steel instead of U-bolts. Flat U-straps are less apt than U-bolts to “point” load the pipe wall. U-strap use is most common when guiding pipe sizes greater than 6-inches diameter.

When U-bolts are used in vertical piping, then two 180° “wear” saddles should be used to protect the pipe around its entire circumference. It is appropriate to gently snug the U-bolt if a 1/8-inch thick rubber pad is positioned between the U-bolt and the saddle. If significant thermal cycles are expected, then the U-bolts should be installed with sufficient clearance to allow the pipe to expand and contract freely. See the “Vertical Riser Clamps” section for additional options in supporting vertical piping.

SECTION 2. SUPPORTS, ANCHORS and GUIDES

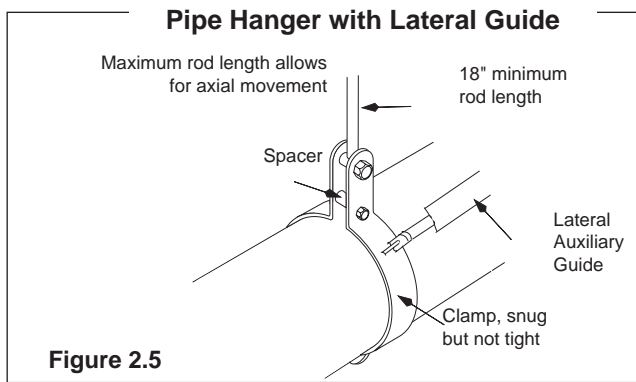

Figure 2.5

Figure 2.5 shows a more sophisticated pipe hanger and guide arrangement. It may be used without wear saddles as long as the tie rod allows free axial movement. The hanger must meet the width requirements in Table 2.0. If a clamp width does not meet the requirements in Table 2.0 or the pipe sizes are greater than 14-inch diameter, then support saddles should be used. See Table 2.1 for support saddle sizing recommendations.

Lateral loading on guides is generally negligible under normal operating conditions in unrestrained piping systems. In restrained piping systems, guides provide the stability required to prevent buckling of pipelines under compressive loads. If the guides are located properly in the pipeline, the loads required to prevent straight pipe runs from buckling will be very small.

Upset conditions can result in significant lateral loads on the guides and should be considered during the design phase by a qualified piping engineer. Water hammer and thermal expansion or contraction may cause lateral loading on guides near changes in direction. Therefore, it is always prudent to protect the pipe from point contact with guides near changes in directions and side runs.

Pipe Hanger with Axial Guide

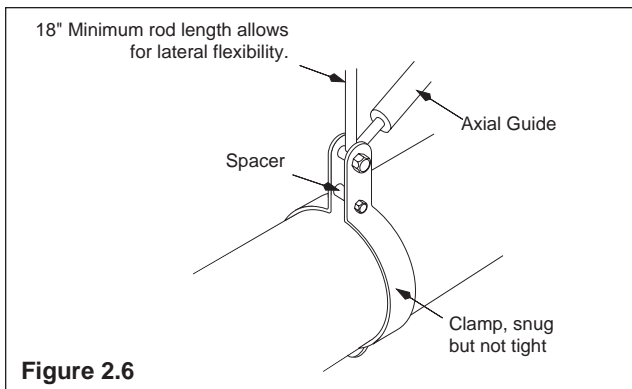

Figure 2.6

Figure 2.6 shows a pipe hanger with an axial guide using a double bolt pipe clamp arrangement. This support provides limited axial stability to unrestrained piping systems.

Pipe lines supported by long swinging hangers may experience instability during rapid changes in fluid flow. Stability of such lines benefit from the use of pipe guides

as shown in Figures 2.5 and 2.6.

The support widths for guided pipe hangers should meet the recommendations in Tables 2.0 & 2.1.

Vertical Riser Clamps

Riser clamps as shown in Figure 2.7 may act as simple supports, as well as guides, depending upon how they are attached to the substructure. The clamp should be snug but not so tight as to damage the pipe wall. The use of an anchor sleeve bonded onto the pipe is required to transfer the load from the pipe to the riser clamp. See the "Anchor Designs" section for detailed information concerning the anchor sleeve or FRP buildup.

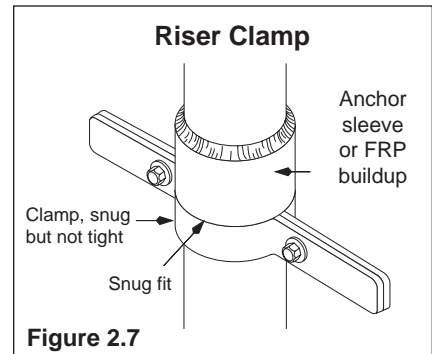

Figure 2.7

It is important to note that this type of clamp only provides upward vertical support. Certain design layouts and operating conditions could lift the pipe off the riser clamp. This would result in a completely different load distribution on the piping system. A pipe designer needs to consider whether the column will be under tension, or in a state of compression. Additional guides may be required to prevent unwanted movement or deflection.

A qualified piping engineer should be consulted to ensure an adequate design.

Riser clamps designed to provide lateral support should incorporate support saddles to distribute the lateral loads.

C. Anchor Design

Anchor Usage

1. To protect piping at "changes-in-directions" from excessive bending stresses.
2. To protect major branch connections from primary pipeline induced shears and bending moments. Particular consideration should be given to saddle and lateral fitting side runs.
3. Installed where fiberglass piping is connected to steel piping and interface conditions are unavailable.
4. To protect a piping system from undesirable movement caused by water hammer.
5. To protect sensitive in-line equipment.
6. To absorb axial thrust at in-line reducer fittings when fluid velocities exceed 7.5 ft/sec.
7. To provide stability in long straight runs of piping.

SECTION 2. SUPPORTS, ANCHORS and GUIDES

To be effective, an anchor must be attached to a substructure capable of supporting the applied forces. In practice, pumps, tanks, and other rigidly fixed equipment function as anchors for fiberglass piping systems.

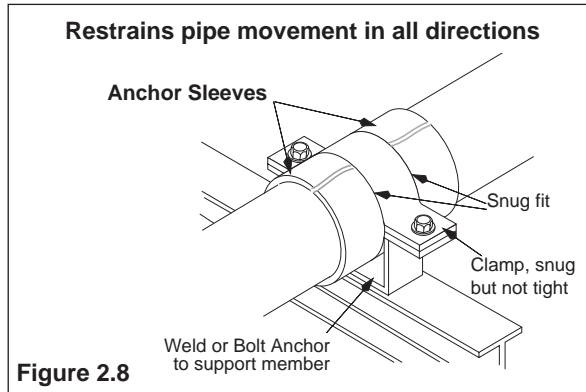

Anchors as previously described are used to provide axial restraint to piping systems. In most cases an anchor provides bi-directional lateral support to the pipe thus acting like both a support and guide. Furthermore, anchors can be designed to provide partial or complete rotational restraint. But, this is not normally the case in practice. Figures 2.8 through 2.11 show typical methods of anchoring fiberglass piping systems.

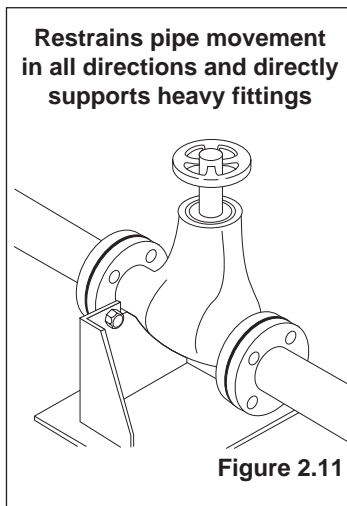
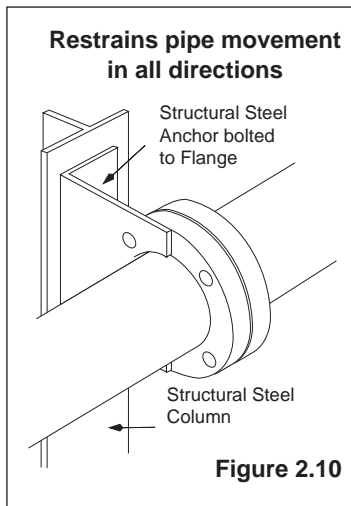
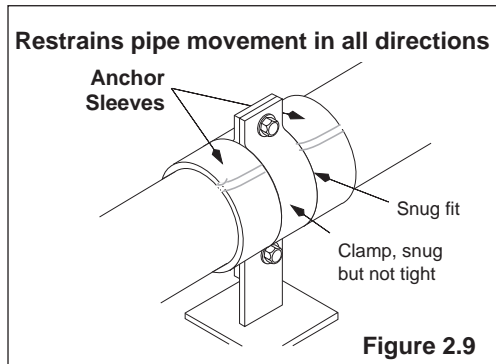

The anchor in Figure 2.9 will provide considerably less lateral stiffness than the anchor in Figure 2.8. The effect of lateral stiffness on the overall system stability should always be considered when selecting an anchor design.

The anchor widths should meet the recommendations for support bracket designs in Table 2.0.

The reactions generated at anchors when restraining large thermal loads can be significant and should be calculated by a qualified piping engineer. The anchors brackets and substructure design should be designed with sufficient stiffness and strength to withstand these loads combined with any other system loads. Other system loads may include water hammer, the static weight of the pipe, fluid and any external loads such as insulation, wind, ice, snow, and seismic.

Anchor Sleeves

An anchor sleeve as shown in Figure 2.12 is necessary to transfer axial load from a pipe body to an anchor bracket. Pairs of anchor sleeves are bonded to the outer surface of a pipe to provide a shear load path around the complete circumference of the pipe body. To restrain pipe motion in two directions, two pairs of anchor sleeves are required. They must be bonded on both sides of an anchor bracket to completely restrain a pipe axially. There are design conditions where

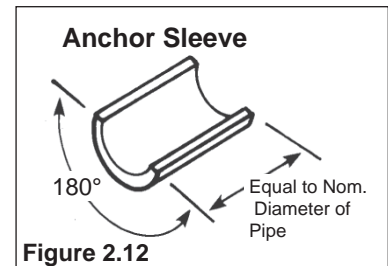

only one set of anchor sleeves is required. The piping engineer should make this determination.

During installation the anchor sleeve end faces must be aligned to mate precisely against the anchor brackets when engaged. If only one of the two halves of an anchor sleeve contacts the anchor bracket, the loading will be off center or eccentric. Eccentric loading will increase the shear stress on the contacted anchor sleeve. It may also cause the pipe to rotate at the anchor resulting in unwanted deflections in the pipe. Refer to Figures 2.8 & 2.9 for typical configurations.

It is important to understand how the load is transferred from the pipe to the anchor brackets. First the axial load is sheared from the pipe wall into the anchor sleeves through the adhesive bond. The load is then transferred from the anchor sleeve by direct contact bearing stress between the end of the anchor sleeve and the anchor bracket which ultimately transfers it to the substructure.

Under no circumstances is the anchor to be tightened down on the pipe surface and used as a friction clamp to transfer load. The pipe should be free to slide until the

SECTION 2. SUPPORTS, ANCHORS and GUIDES

anchor sleeves contact the anchor bracket to transfer the load. Piping engineers often take advantage of this anchoring procedure by allowing the pipe to slide a small amount before contacting the anchor. This effectively reduces restrained loads.

Split repair couplings, split fiberglass pipe sections or hand layups of fiberglass and resin are commonly used as anchor sleeves. Contact your fiberglass distributor to determine the most appropriate choice for Fiber Glass Systems' wide variety of piping products.

D. Piping Support Span Design

A support span is the distance between two pipe supports.

Proper support span lengths ensure the pipe deflections and bending stresses are within safe working limits. For static weight loads, it is standard practice to limit the maximum span deflection in horizontal pipe lines to Ω " and the bending stresses to $1/8$ of the ultimate allowable bending stress. Fiber Glass Systems applies these design limits to the engineering analysis used to determine the allowable support spans.

Span Analysis Methodology

The maximum allowable piping support spans are determined using the "Three Moment Equations" for uniformly loaded continuous beams. The equations may be modified to represent various end conditions, load types and even support settlements. Refer to Appendix A for the fundamental equations. Fiber Glass Systems uses these equations to calculate the bending moments in piping spans. The pipe bending stresses and deflections are then evaluated for compliance with the aforementioned design criteria.

To avoid lengthy engineering calculations, FGS individual product bulletins contain recommended piping support span lengths. These span lengths are easily modified to match fluid specific gravity, operating temperatures and end conditions. Figures 2.13 and 2.14 provide span adjustment factors for various end conditions found in most horizontal piping system layouts. Tables for fluid specific gravity and temperature adjustment factors are product unique. Please refer to Smith Fibercast's product data bulletins for detailed design information.

FGS software *Success By Design* quickly calculates support spans for uniformly loaded piping systems. *Success By Design* takes into consideration product type, temperature, specific gravity, uniform external loads, and end conditions as shown in Figures 2.13 and 2.14.

Complex piping system designs and load conditions may require detailed flexibility and stress analysis using finite element modeling. The project design engineer must determine the degree of engineering analysis required for the system at hand.

Figure 2.13 Piping Span Adjustment Factors With Unsupported Fitting at Change in Direction

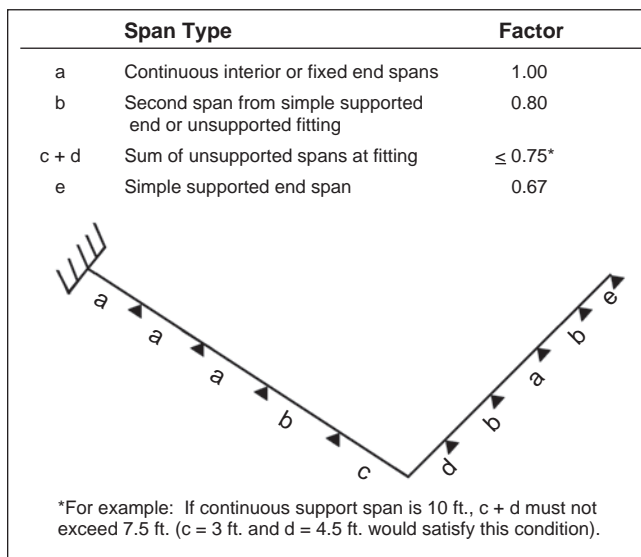
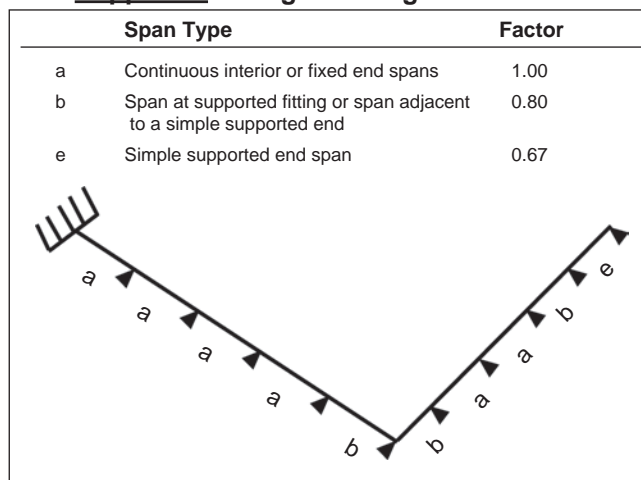

Figure 2.14 Piping Span Adjustment Factors With Supported Fitting at Change in Direction



Summary

1. Do not exceed the recommended support span.
2. Support valves and heavy in-line equipment independently. This applies to both vertical and horizontal piping.
3. Protect pipe from external abrasion.
4. Avoid point contact loads.
5. Avoid excessive bending. This applies to handling, transporting, initial layout, and final installed position.
6. Avoid excessive vertical run loading. Vertical loads should be supported sufficiently to minimize bending stresses at outlets or changes in direction.
7. Provide adequate axial and lateral restraint to ensure line stability during rapid changes in flow.

SECTION 3. Temperature Effects on Fiberglass Pipe

SYSTEM DESIGN

The properly designed piping system provides safe and efficient long-term performance under varying thermal environments. The system design dictates how a piping system will react to changes in operating temperatures.

The unrestrained piping system undergoes expansion and contraction in proportion to changes in the pipe wall mean temperature. Fiberglass piping systems that operate at or near the installation temperature are normally unrestrained designs, where the most important design consideration is the basic support span spacing. Since few piping systems operate under these conditions, some provisions must be made for thermal expansion and contraction.

The simplest unrestrained piping systems use directional changes to provide flexibility to compensate for thermal movements. When directional changes are unavailable or provide insufficient flexibility, the use of expansion loops or expansion joints should be designed into the system to prevent overstressing the piping system. These systems are considered unrestrained even though partial anchoring and guiding of the pipe is required for proper expansion joint, expansion loop performance and system stability.

The fully restrained "anchored" piping system eliminates axial thermal movement. Pipe and fittings generally benefit from reduced bending stresses at directional changes. Restrained systems develop internal loads required to maintain equilibrium at the anchors due to temperature changes. When the pipe is in compression, these internal loads require guided supports to keep the pipe straight. Thus, the commonly referred to name of restrained systems is "anchored and guided". Anchored and guided systems have anchors at the ends of straight runs that protect fittings from thermal movement and stresses.

Anchors at directional changes (elbows and tees) transmit loads to the support substructure. Special attention should be given to these loads by the piping engineer to ensure an adequate substructure design. When anchors are used to break up long straight runs, the loads between them and the substructure are generally negligible. The axial restraining loads are simply balanced between the two opposing sides of the pipeline at the anchor.

THERMAL PROPERTIES & CHARACTERISTICS

The reaction of fiberglass piping to changes in temperature depends on two basic material properties, the thermal "coefficient of expansion"(a) and the axial moduli of elasticity. The composite nature of fiberglass piping results in two distinctive axial moduli of elasticity. They are the axial compression and axial tensile moduli. Systems installed at ambient temperature and operated at higher temperatures will generate internal compression piping stress when anchored. Although this is the most common engineering design condition, the piping engineer should not overlook the opposite thermal condition that generates tensile stresses.

The thermal properties of fiberglass pipe distinguish it from steel in important ways. The coefficient of expansion is roughly twice that of steel. This translates to twice the thermal movement of steel in unrestrained systems. The axial compression modulus of elasticity of fiberglass pipe varies from 3% to 10% that of steel. When restraining thermal movements in fiberglass piping the anchor loads would be 1/5 or less than the loads created by a same size and wall thickness in steel piping system.

Thermoplastic pipe coefficients of expansion are typically more than four times that of fiberglass. The elastic modulus of thermoplastic piping is considerably smaller than the moduli of fiberglass and steel. The modulus of elasticity of thermoplastic pipe decreases rapidly as the temperatures increases above 100°F. This results in very short support spans at elevated temperatures. A restrained thermoplastic piping systems operating at elevated temperatures is very susceptible to buckling thus requiring extensive guiding.

It is important to properly determine the temperature gradient. The gradient should be based on the pipeline temperature at the time that the system is tied down or anchored. If the operating temperature is above this temperature, then the gradient is positive and conversely if it is less than this temperature, then the gradient is negative. Many piping systems will see both positive and negative temperature gradients that must be considered during the system design.

FGS software *Success By Design* performs thermal analysis on fiberglass piping systems based on the methods discussed in this section. The benefits of using *Success By Design* are not only ease of use, but increased analysis accuracy. The software evaluates the fiberglass material properties at the actual operating temperatures, eliminating the conservatism built into charts and tables designed to cover worst case scenarios for all designs.

SECTION 3. TEMPERATURE EFFECTS

FUNDAMENTAL THERMAL ANALYSIS FORMULAS

A. Thermal Expansion and Contraction

The calculation of thermal expansion or contraction in straight pipelines is easily accomplished using the following equation.

$$\text{Eq. 19} \quad \delta := \alpha \cdot L \cdot (T_o - T_i)$$

Where:

- d = Length change, in (m)
- a = Thermal coefficient of expansion, in/in°F (m/m/°C)
- L = Pipe length, in (m)
- To = Operating temperature, °F (°C)
- Ti = Installation temperature, °F (°C)
- Final tie-in or completion temperature.
- (To - Ti) is the temperature gradient

B. Anchor Restraint Load

The calculation of the restrained load in a pipeline between two anchors is easily accomplished using the following equation.

$$\text{Eq. 20} \quad Fr := \alpha \cdot A \cdot E \cdot (T_o - T_i)$$

Where:

- Fr = Restraining force, lb (N)
- a = Thermal coefficient of expansion, in/in°F (m/m/°C)
- A = Reinforced pipe wall cross sectional area, in² (m²)
- To = Operating temperature, °F (°C)
- Ti = Installation temperature, °F (°C)
- Final tie-in or completion temperature.
- (To - Ti) Temperature gradient
- E = Axial modulus of elasticity, lb/in² (N/m²)
- The compression modulus should be used with a positive temperature change (To>Ti) and the tensile modulus with a negative temperature change (To<Ti).

The reactions on the external support structure at internally spaced anchors in long straight runs are negligible because the in-line forces balance. However, the anchors at the end of straight runs will transmit the full load to the support structure.

C. Guide Spacing

The Guide spacing calculations are derived from Euler's critical elastic buckling equation for a slender column with pivot ends.

$$\text{Eq. 21} \quad L_g := \sqrt{\frac{2 \cdot \pi \cdot E \cdot I}{Fr}}$$

Where:

- Lg = Guide spacing, in (m)
- Fr = Restraining force, lb (N)
- E = Bending modulus of elasticity, lb/in² (N/m²)
- I = Pipe area moment of inertia, in⁴ (m⁴)
- p = Pi ~3.14159

FLEXIBILITY ANALYSIS AND DESIGN

There are four basic methods of controlling thermal expansion and contraction in above ground piping systems. They are:

1. Anchoring and Guiding
2. Directional Changes
3. Expansion Loops
4. Mechanical Expansion Joints

The use of anchors and guides as discussed earlier depends on restraining thermal growth. Directional changes, expansion loops and mechanical expansion joints use component flexibility to safely absorb thermal movements.

A. Directional Change Design

The flexibility analysis of a directional change is based on a guided cantilever beam model. The cantilever must be of sufficient length to ensure the pipe will not be overstressed while absorbing the thermal movement. This is accomplished by satisfying the following equations.

Eq. 22 Based on pipe allowable bending stress

$$L := \sqrt{\frac{K \cdot \delta \cdot E \cdot OD}{\sigma}}$$

Where:

- K = 3, Guided cantilever beam coefficient
- L = Length of cantilever leg, in (m)
- E = Pipe beam bending modulus of elasticity, lb/in²(N/m²)
- OD = Pipe outer diameter, in (m)
- d = Total deflection to be absorbed, in (m)
- s = Pipe allowable bending stress, lb/in²(N/m²)

Eq. 23 Based on fitting allowable bending moment

$$L := \sqrt{\frac{K \cdot E \cdot I \cdot \delta}{M}}$$

Where:

- K = 6, Guided cantilever beam coefficient
- L = Length of cantilever leg, in(m)
- E = Pipe beam bending modulus of elasticity, lb/in²(N/m²)
- I = Pipe reinforced area moment of inertia, in⁴(m⁴)
- d = Total deflection to be absorbed, in(m)
- M = Fitting allowable bending moment, in-lb (N-m)

Minor out of plane rotation of the elbow should be allowed to minimize bending moments on the elbow.

The use of the guided cantilever beam equation results in conservative leg lengths.

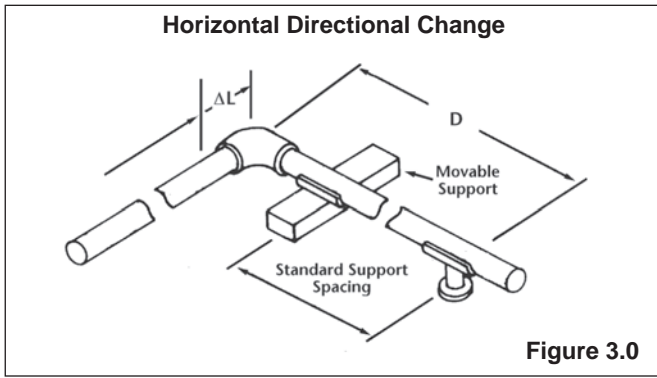

Figure 3.0

See Figure 3.0 for a typical horizontal directional change layout.

B. Expansion Loop Design

The flexibility of an expansion loop is modeled using two equal length guided cantilever beams. Each cantilever absorbs half of the thermal expansion or contraction. The cantilevers must be of sufficient length to ensure the pipe and fittings will not be overstressed. Determination of the minimum required lengths is accomplished by satisfying equation 22 with $K=1.5$ and equation 23 with $K=3$. These equations should be used with the total deflection ($d=d_1+d_2$) to be absorbed by both expansion loop legs.

See Figure 3.1 for a typical expansion loop layout.

The pipe should be guided into the expansion loop as shown in Figure 3.1. The positioning of two guides on each side of the expansion loop is required to maintain proper alignment. The recommended guide spacing is four and fourteen nominal pipe diameters from the elbow for the first and second guides respectively.

To achieve the required flexibility only 90°elbows should be used in directional changes and expansion loops. The substitution of 45° elbows will result in an unsatisfactory design.

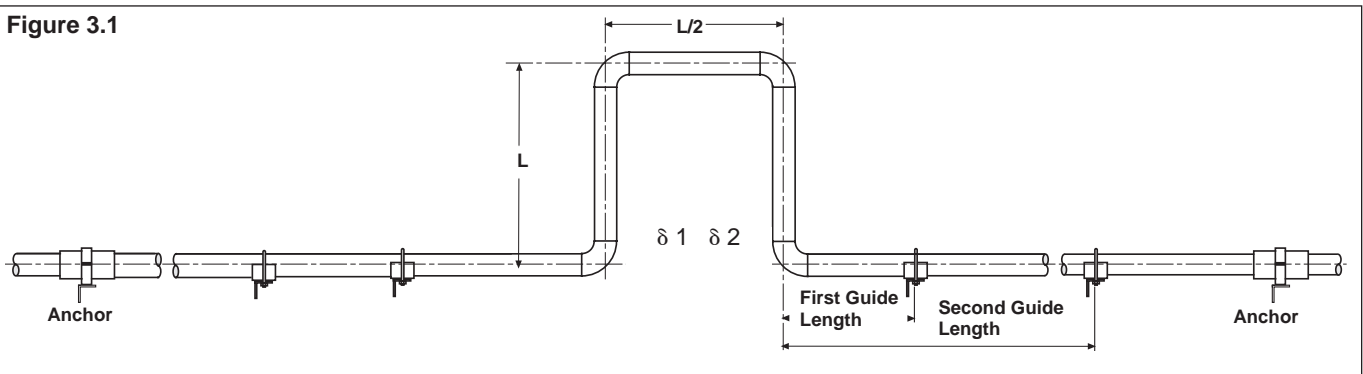

Figure 3.1

C. Expansion Joint Design

Mechanical expansion joint use requires the engineer to determine the complete range of thermal movement expected in the system. This is accomplished by calculating the maximum thermal expansion and thermal contraction for the operating conditions. The mechanical expansion joint must be capable of absorbing the full range of thermal movement with an appropriate margin of safety. During installation the set position must be determined to ensure the expansion joint will accommodate the entire range of movement. This is accomplished using the following equation.

$$\text{Eq. 24 } \text{SetPoint} := R \cdot \text{Travel}$$

Where:

- Set Point = Installed position of mechanical expansion joint "Distance from the joint being fully compressed", in(m)
- Travel = Mechanical expansion joint maximum movement, in(m)

$$\text{Eq. 25 } R := \frac{T_i - T_{\min}}{T_{\max} - T_{\min}}$$

- R = Thermal ratio
- T_i = Installation tie-in temperature, F°(C°)
- T_{min} = Minimum operating temperature, F°(C°)
- T_{max} = Maximum operating temperature, F°(C°)
- T_{min} ≤ T_i

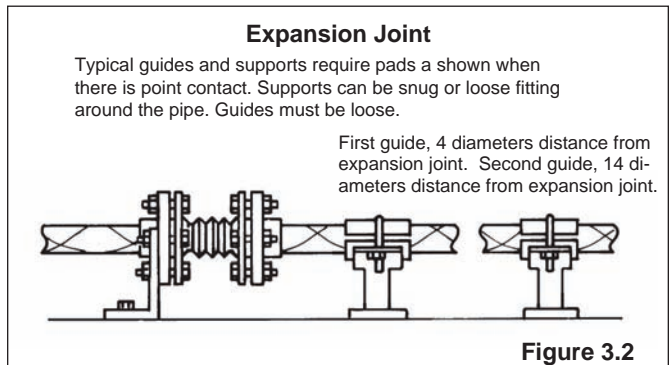

Figure 3.2

SECTION 3. TEMPERATURE EFFECTS

Example Problem:

Determine the "Travel" and "Set Point" for the following conditions.

Ti = 75°F, Tmin = 45°F, Tmax = 145°F, R = 0.3
 Pipe total thermal movement is 6 inches.
 Design factor 1.5

Expansion joint "Travel" required is 9 inches (6 x 1.5).
 The "Set Point" should be 0.3 x 9 = 2.7 inches (compression). This set point allows for 1.5 times the thermal growth or contraction for the given operating conditions. See Figure 3.2 for a typical expansion joint layout.

The proper selection of an expansion joint design depends on the available activation forces generated by the piping system. Equation 20 should be used to determine the fully restrained activation force capability of the piping system. If a mechanical expansion joint requires an activation load higher than the fully restrained activation force then the expansion joint will not function. The expansion joint activation force in practice should not exceed 1/4 of the loads in a fully restrained piping system. Mechanical expansion joint requiring higher activation forces may not provide sufficient flexibility to warrant its use.

It is prudent engineering practice to determine if the piping system will require guiding under the compression activation forces. Equation 21 should be used to determine the guide spacing.

D. Heat Tracing

Heat tracing is the practice of heating a piping system to prevent freezing or cooling of a process line. Steam tracing and electrical heat tapes are typical methods of heat tracing fiberglass piping. The maximum heat tracing temperature is governed by one of three criteria:

(1) The mean wall temperature must not exceed the maximum temperature rating of the pipe,

$$\text{Eq. 26} \quad \frac{T_{in} + T_{ra}}{2} \leq T_{pr}$$

(2) The maximum tracing element temperature must not exceed 100°F(55.6°C) above the temperature rating of the pipe

$$\text{Eq. 27} \quad T_{pr} + 100 \leq T_{ra}$$

(3) The maximum recommended temperature for the service chemical must not be exceeded at the surface of the pipe inner wall.

$$\text{Eq. 28} \quad T_{in} - T_{cr} \leq 0$$

For stagnant flow, the temperature of the fluid and inner surface of the pipe can be assumed to equal the trace temperature. This assumption is valid if the heat trace element provides sufficient energy to overcome heat losses to the environment. For the stagnant or no flow condition, equations 26 and 27 are used to determine the maximum allowable heat trace temperature.

$$\text{Eq. 29} \quad T_{in} := T_{cr}$$

Therefore:

$$\text{Eq. 30} \quad T_{ra} := T_{cr}$$

For Eq. 26-30:

T_{in} = Pipe inner surface temperature, °F(°C)

T_{ra} = Heat trace element temperature, °F(°C)

T_{pr} = Pipe temperature rating, °F(°C)

T_{cr} = Chemical resistance temperature rating of pipe, °F(°C)

Determination of the pipe inner wall temperature under active flow conditions depends on flow rate, specific heat of the fluid, temperature of fluid entering pipe, conduction through the pipe wall, external environmental heat losses and the heating element capacity. The complexity of this analysis is beyond the scope of this manual. Therefore, prudent engineering practices should be employed to determine the safe heat tracing temperatures under these conditions.

These criteria are most easily explained by the following examples:

Example: What is the maximum heat tracing temperature allowed to maintain a 5% caustic solution at 95°F inside RED THREAD II pipe rated to 210°F?

The three governing criteria must be considered in order to determine the maximum tracing element temperature.

Step I: Solving for criterion (1) equation 26 is applied.

$$T_{ra} \leq 2 \cdot T_{pr} - T_{in}$$

$$T_{ra} \leq 2 \cdot 210 - 95$$

$$T_{ra} \leq 325$$

Rearranging and solving for the maximum trace temperature, T_{ra} we get 325°F.

Step II: Solving for criterion (2) equation 27 is applied.

$$T_{ra} \leq T_{pr} + 100$$

$$T_{ra} \leq 210 + 100$$

$$T_{ra} \leq 310$$

Rearranging and solving for the maximum trace temperature, T_{ra} we get 310°F.

Step III: Solving for criterion (3) equation 30 the stagnant flow condition is applied.

$$T_{ra} = T_{c1}$$

Therefore the maximum allowable heat trace temperature equals the maximum chemical resistance temperature for the piping. Referencing FGS, *Chemical Resistance Guide*, Bulletin No. E5615, RED THREAD II pipe is rated to 100°F in 5% caustic. Therefore the maximum heat trace temperature is 100°F.

However, if the fluid were flowing into the pipeline at temperatures below 100°F, then the heat trace temperature would be higher than 100°F. A thorough heat transfer analysis would be required to determine the appropriate heat trace temperature for this condition.

The maximum heat trace temperature for stagnant flow is 100°F, the lowest temperature calculated using the three criteria.

E. Thermal Conductivity - Heat Gain or Loss

The thermal conductivity of fiberglass piping is approximately 1/100 that of steel, making it a poor conductor of heat compared to steel. However, the use of insulation to prevent heat loss or gain is recommended when there are economic consequences due to heat loss or gain. Typical fiberglass thermal conductivity values vary from 0.07-0.29 BTU/(Ft.)(Hr.)(°F).

F. Thermal Expansion in Buried Pipe

Soil restraint inherently restrains movement of buried fiberglass pipelines because these pipes develop relatively small forces during a temperature change. Special precautions (thrust blocks, guides, expansion joints, etc.) for handling thermal expansion are not necessary if the pipe is buried at least two to three feet and the bedding material is of a soil type capable of restraining the line. Sand, loam, clay, silt, crushed rock and gravel are suitable bedding for restraining a pipeline; however, special precautions must be taken to properly anchor the pipe in swamps, bogs, etc. where bedding might easily shift and yield to even the low forces developed in fiberglass pipe.

G. Pipe Torque Due to Thermal Expansion

Torsion shear stresses in piping systems containing multiple elevation and directional changes normally do not have to be considered in pipe analysis. The allowable bending moments are much lower than the allowable torsional moments in a pipe. Therefore, bending moments in a pipe leg reacted by torsion in a connecting pipe will be limited by the bending moment capability of the pipe not the torsional load. Computer modeling is recommended for this sophisticated level of piping system analysis.

SECTION 4. PIPE BURIAL

SECTION 4. Pipe Burial

INTRODUCTION

The guidelines in this section pertain to the design and burial of fiberglass pipe. The structural design process assumes the pipe will receive adequate support in typically encountered soil conditions. Recommendations for trenching, selecting, placing and compacting backfill will be discussed.

The successful installation depends on all components working together to form a sound support system. Therefore, once a pipe is selected, it is of utmost importance to carefully review the native soil conditions, select the backfill material and closely monitor the trenching and installation process. Properly positioned and compacted bedding and backfill reduces pipe deformations maximizing long-term performance of a buried pipeline.

Detailed design and installation data for buried fiberglass piping systems may be found in AWWA M45, *Manual of Water Supply Practices, Fiberglass Pipe Design, First Edition*. Contact Fiber Glass Systems applications engineer for detailed burial calculations.

PIPE FLEXIBILITY

The response of fiberglass pipe to burial loads is highly dependent on the flexibility of the pipe walls. The best measure of pipe flexibility can be found using the "pipe stiffness" value as defined and determined by ASTM D2412 tests.

Pipe with pipe stiffness values greater than 72 psi typically resist native backfill loads with minimal pipe deformation. The pipe stiffness of small diameter fiberglass pipe, 1 to 8 inch diameters, typically meets or exceeds 72 psi. Two to three feet of native backfill cover with a soil modulus greater than or equal to 1,000 psi is generally sufficient to protect this category of pipe from HS-20 vehicular and dead weight soil loads.

Pipe that is buried under concrete or asphalt roadways that support vehicular loads requires less cover. Design data and burial depth recommendation for specific piping can be found in Smith Fibercast product bulletins and installation handbooks. Smith Fibercast's Manual No. B2160 contains special installation instructions for UL Listed RED THREAD IIA piping commonly used under pavements.

Pipe with pipe stiffness values less than 72 psi, are considered flexible and are more susceptible to the effects of poor compaction or soil conditions. Because of this, larger diameter piping requires detailed attention during the design and installation of buried pipelines.

BURIAL ANALYSIS

Pipe burial depth calculations are based on Spangler's deflection equation and Von Mises's buckling equation as outlined in AWWA M45. Application of these methods is based on the assumption that the design values used for bedding, backfill and compaction levels will be achieved with good field practice and appropriate equipment. If these assumptions are not met, the deflections can be higher or lower than predicted by calculation.

A. Soil Types

A soil's ability to support pipe depends on the type of soil, degree of compaction and condition of the soil, i.e. density and moisture content. A stable soil is capable of providing sufficient long-term bearing resistance to support a buried pipe. Unstable soils such as peat, organic soil, and highly expansive clays exhibit a significant change in volume with a change in moisture content. Special trenching and backfill requirements are necessary when the native soil is unstable. Some guidelines to aid the engineer in determining the stability at a particular site follow:

1. For cohesive soils or granular-cohesive soils, if the unconfined compressive strength per ASTM D2166 exceeds 1,500 lb/ft², the soil will generally be stable.
2. For cohesive soils, if the shear strength of the soil per ASTM D2573 is in excess of 750 lb/ft², the soil will generally be stable.
3. For sand, if the standard penetration "Blow" value, N, is above 10, the soil will generally be stable.

Soils types are grouped into "stiffness categories" (SC). They are designated SC1 through SC5. SC1 indicates a soil that provides the highest soil stiffness at any given Proctor density. An SC1 classified soil requires the least amount of compaction to achieve the desired soil stiffness. The higher numbered soil classifications (SC2-SC4) become, the more compaction is required to obtain specific soil stiffness at a given Proctor density. The SC5 soils are unstable and should not be used as backfill or bedding. Decaying organic waste and frozen materials fall in the SC5 category. Lists of recommended backfill materials are shown in Table 4.0.

SECTION 4. PIPE BURIAL

TABLE 4.0 Recommended Bedding and Backfill Materials

Stiffness Category ¹	Pipe Zone Backfill Material ^{2,5}	Degree of Compaction ³ %
SC1	Crushed rock ⁴ with ≤15% sand, maximum 25% passing the 3/8" sieve and maximum 5% fines	As Dumped (No compaction required)
SC2	Coarse-grained soils with ≤ 12% fines	75-85
SC3	Coarse-grained soils with >12% fines	85-95
SC3	Fine-grained soils with >12% fines	85-95
SC4	Fine-grain soils with medium to no plasticity with <30% coarse-grained particles	>95

- 1 AWWA M45 soil stiffness categories
- 2 Maximum particle size of æ inch for all types.
- 3 Compaction to achieve a soil modulus of 1,000 psi.
- 4 Pea gravel is a suitable alternative.
- 5 A permeable fabric trench liner may be required where significant ground water flow is anticipated.

B. Soil Modulus Considerations

The soil modulus is a common variable that is very important to fiberglass piping burial analysis regardless of the soil type. Extensive research and engineering analysis has shown that a soil modulus of 1,000 psi provides very good support to fiberglass pipe. Table 4.0 shows the degree of compaction based on the Proctor density to obtain a soil modulus of 1,000 psi. It is worth noting that for all stiffness categories this soil modulus may be obtained, although with varying compaction requirements.

Although a modulus of 1,000 psi is preferred, values as low as 750 psi will provide sufficient support to fiberglass pipe if it is properly engineered and installed.

TRENCH EXCAVATION AND PREPARATION

A. Trench Size

The purpose of the trench is to provide working space to easily install the pipeline. The trench depth must account for the bedding thickness, pipe height and backfill cover. Trench widths must accommodate workers and their tools, as well as allow for side bedding and backfill. Nominal trench widths listed in Table 4.1 are satisfactory for most installations.

B. Trench Construction

1. Solid rock conditions

If solid rock is encountered during trench construction, the depth and width of the trench must be sufficient to allow a minimum of 6-inches of bedding between the rock and pipe surface.

2. Granular or loose soils

These types of soils are characterized by relatively high displacement under load, and soft to medium soft consistencies. The walls of trenches in this type of soil usually have to be sheeted or shored, or the trench made wide enough to place a substantial amount of bedding material in order to prevent excessive

TABLE 4.1 Nominal Trench Widths

Pipe Size (In.)	Minimum Width (In.)	Maximum Width* (In.)
2	18	26
3	18	27
4	18	28
6	20	30
8	23	32
10	25	34
12	28	36
14	31	38
16	33	40
18	36	42
20	39	44
24	44	48
30	52	56
36	60	64
42	66	70
48	72	80
54	78	86
60	84	96
72	96	108
84	108	120

* Trench widths may be wider depending on soil conditions.

Trench for Soft and Medium Consistency Soils

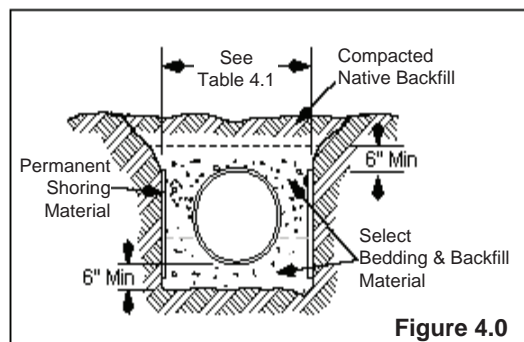

deformation in the pipe sides (see figures 4.0 & 4.1). In some cases, additional depth or supplementary trench foundation material may be required.

SECTION 4. PIPE BURIAL

Trench for Granular Type Soils

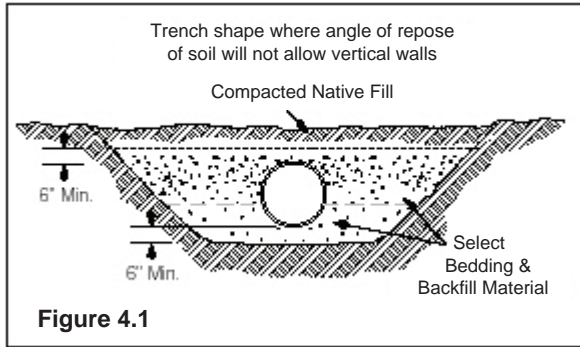

Figure 4.1

3. Unstable soils

Unstable soils require special precautions to develop a stable environment for fiberglass pipe. See Figure 4.2 for a recommended trenching procedure. SC1 bedding and backfill material should be used with a permeable, fabric liner to prevent migration of fill into the native soil. Due to the unpredictable nature of unstable soils a soils engineer should be consulted for project specific design recommendations.

Wide Trench for Very Soft or Unstable Soils

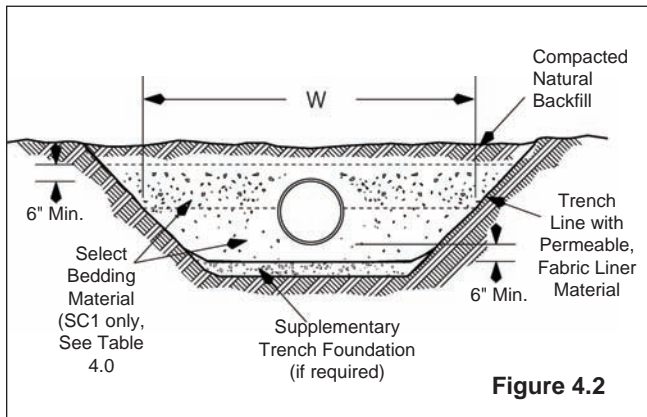

Figure 4.2

C. Maximum Burial Depth

Surface loads do not usually affect the maximum burial depths. The maximum burial depth ultimately depends on the soil backfill modulus. When burying pipe in stable soil with a backfill modulus of 1,000 psi, the maximum allowable depth of cover is normally 15-20 feet. When burying pipe in soil with a backfill modulus of 700 psi, the maximum allowable cover is seven feet. Although the above maximum burial depths are typical, Smith Fibercast will design custom products for your application. Reference Smith Fibercast's product bulletins for specific product recommendations.

D. Roadway Crossing

Pipe passing under unpaved roadways should be protected from vehicular loads and roadbed settlement. Burial depths under stable roadbeds should be determined per AWWA M45 for vehicular traffic. If the roadbed is unstable or burial-depths are shallow then steel or concrete sleeves are required see Figure 4.3.

Typical Roadway Crossing

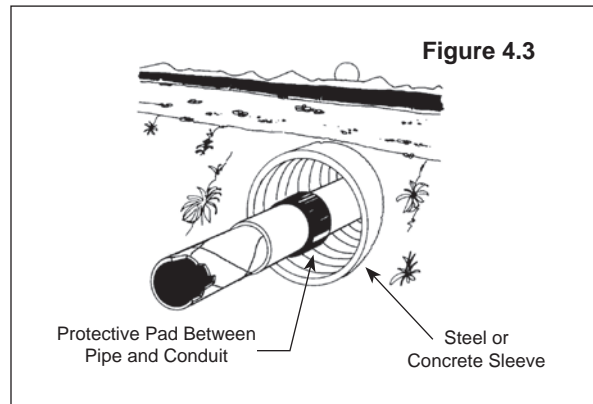

BEDDING AND BACKFILL

A. Trench bottom

The trench bottom is the foundation of the pipe support system. Select bedding material is required for flexible fiberglass pipelines. The bedding should be shaped to conform to the bottom ° pipe diameter. Proper placement and compaction of the bedding is required to ensure continuous pipe support. See Figures 4.4, 4.5 & 4.6 for examples of standard bedding practices.

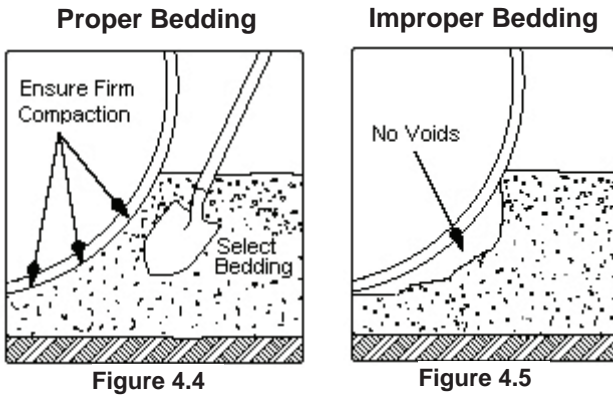

Figure 4.4

Figure 4.5

Bedding and Backfill for Firm or Hard Native Soil

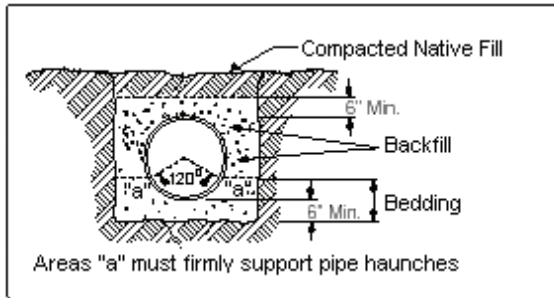

Figure 4.6

B. Backfill materials

Backfill material at the sides of the pipe is to be added in lifts, not to exceed 6-inches at a time, mechanically compacted to the required density and continued to 6-inches above the top of the pipe. The degree of compaction is dependent upon the type of fill material used. Water flooding for compaction is not recommended, nor is compacting the fill material while it is highly saturated with water.

Proper compaction of the backfill material is required for pipeline stability and longevity. Sand, pea gravel or crushed rocks are the recommended fill materials for Fiber Glass Systems pipe compacted per Table 4.0.

If excavated native material meets the requirements listed in Table 4.0, it may be used for bedding and backfill. Soils containing large amounts of organic material or frozen materials should not be used. If there is any question as to the suitability of the native soil, a soil engineer should be consulted.

C. Backfill cover

The cover layers above the backfill should be applied in lifts of 6 inches. Native soil may be used, provided it is not unstable type SC5 soil. This includes soils loaded with organic material or frozen earth and ice. Each lift should be compacted to a Proctor Density to achieve a 1,000-psi modulus per Table 4.0. Lifts applied 18 inches or more above the top of the pipe may be applied in 12-inch layers provided there are not chunks of soil larger than 12 inches. Again, each layer is to be compacted to the required density. Lift heights should never exceed the capacity of the compaction equipment.

Heavy machinery should not be allowed to cross over trenches unless completely covered and compacted.

D. High water table

Areas with permanent high water tables are usually coincident with very poor soil conditions. In most of these areas, it will be necessary to use crushed rock or pea gravel as the bedding and backfill material. In addition, permeable fabric trench liner should be used to prevent migration of the fill material into the native soil. In extreme cases such as soft clay and other plastic soils, it will be necessary to use "Class A" bedding. (See Figure 4.7). Also, if the depth of the pipe and the depth of cover is less than one diameter, tie downs or concrete encasement is recommended in sufficient quantity to prevent flotation.

Areas prone to flooding or poor draining soil should be treated similar to high water table areas.

Class "A" Bedding

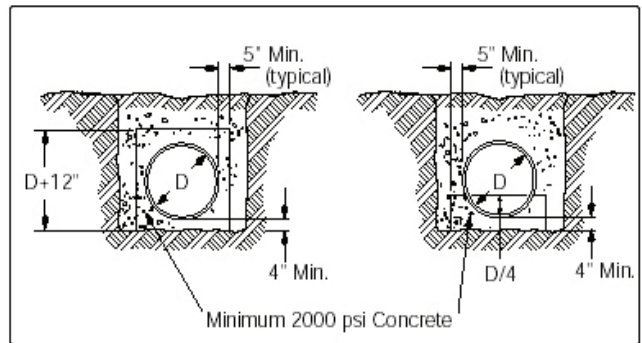

SECTION 5. OTHER CONSIDERATIONS

SECTION 5. Other Considerations

A. ABRASIVE FLUIDS

Fiber Glass Systems piping systems are used to convey abrasive fluids that may also be corrosive. Since fiberglass pipe does not depend upon a protective oxide film for corrosion resistance, it is not subject to the combination of corrosion and abrasion that occurs with metals.

The effects of abrasive fluids on any piping system are difficult to predict without test spools or case history information. Particle size, density, hardness, shape, fluid velocity, percent solids, and system configuration are some of the variables that affect abrasion rates. Standard fiberglass piping with a resin-rich liner can generally handle particle sizes less than 100 mesh (150 micron) at flow rates up to 8 ft./sec. The abrasion resistance can be improved by adding fillers such as fine silica, silicon carbide, or ceramic to the abrasion barrier (such as with SILVER STREAK, F-CHEM, and CERAM CORE products). Wear resistance of fiberglass fittings can be improved by using long-radius fittings.

Since each abrasive service application is different and peculiar to its industry, please consult your local Fiber Glass Systems representative for a recommendation.

B. LOW TEMPERATURE APPLICATIONS

Fiberglass pipe is manufactured with thermosetting resin systems that do not become brittle at low temperatures, as do thermoplastic materials. Fiber Glass Systems pipe and fittings can be used for low temperature applications such as liquid gases (refer to Bulletin No. E5615 for compatibility with liquid gases). Tensile tests performed at -75°F(-59.4°C) actually show an increase in strength and modulus. Typical low temperature applications are the conveyance of fuel, oil, and other petroleum production applications in Alaska.

C. PIPE PASSING THROUGH WALLS OR CONCRETE STRUCTURES

The design of wall penetrations must consider the possible effects of wall settlement and the resulting reactions on the pipe body. Wall penetrations below grade must also be sealed to prevent water seepage. Typically fiberglass pipe is sealed into the wall opening with an epoxy

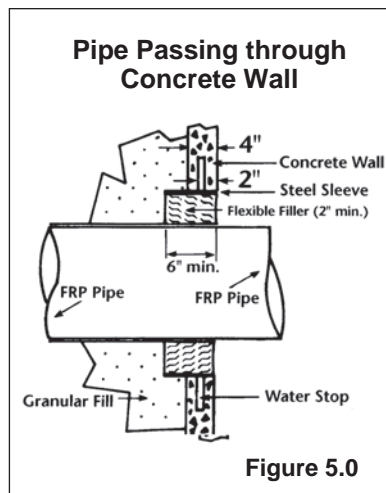

grout material such as if manufactured by ITW Devcon Corporation, Danvers, MA. Fiberglass piping systems should be designed with sufficient flexibility near wall penetrations to minimize reactions to slight wall movements. To prevent leakage around the grout, it is common to embed a steel sleeve with a water-stop during the wall construction (Figure 5.0).

The use of flexible seals between the pipe and wall penetration is a standard practice used to protect fiberglass pipe from abrasion and minimize effects of wall movements. A segmented rubber seal such as Link-Seal® manufactured by Thunderline/Link-Seal, 19500 victor Parkway, Suite 275, Livonia, MI 48152 is commonly used with fiberglass pipe. When available, O-ring sealed joints may be incorporated into the piping system at wall penetrations as shown in Figure 5.1.

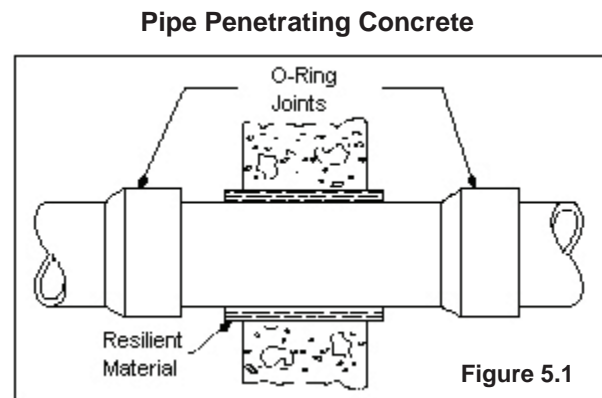

If the pipe is not sealed into the wall, it must be protected from surface abrasion. A heavy gage sheet metal sleeve will provide sufficient protection.

D. PIPE BENDING

Pipe is often bent during transportation, handling and during installation to match trenching contours, etc. As long as the minimum bending radius is not exceeded, these practices will not harm the pipe. Minimum bending radius values are unique to product type and diameter. Therefore, Smith Fibercast piping bulletins must be referred to for accurate data.

Bending of pipe with in-line saddles, tees, or laterals should be avoided. Bending moments in the pipe will create undesirable stresses on the bonded joints and fittings.

© Link-Seal is registered trademark of Thunderline/Link-Seal

E. STATIC ELECTRICITY

The generation of static electricity is not a problem in most industrial applications. The effects of static electricity usually become a design problem only if a dry, electrically non-conductive gas or liquid is piped at high velocity through an ungrounded system.

The generation of static electricity under fluid flow conditions is primarily related to the flow rate, ionic content of the fluid, material turbulence, and surface area at the interface of the fluid and the pipe. The rate of electrostatic generation in a pipe increases with increasing length of pipe to a maximum limiting value. This maximum limiting value is related to fluid velocity and is greater for high velocities. Highly refined hydrocarbons, such as jet fuels, accumulate charges more rapidly than more conductive hydrocarbons, such as gasoline. However, the rate of charge buildup in buried Smith Fibercast piping systems handling jet fuels at a maximum flow velocity of 5 ft/sec is such that special grounding is not necessary.

Static charges are generated at approximately the same rate in fiberglass piping and metallic pipe. The difference in the two systems is that the charge can be more easily drained from a metal line than from a fiberglass line. Under the operating conditions encountered in most industrial applications, any static charge generated is readily drained away from the pipe at hangers or by other contact with the ground, and any small charge in the fluid is drained away at metallic valves and/or instrumentation lines.

Fiber Glass Systems manufactures an electrically conductive piping system that should be employed when static electricity is a critical design parameter.



Occasionally in piping a dry gas at high velocity, a charge may build up on an ungrounded valve. If this charge is not drained off by humid air, it can shock personnel who come in contact with the valve. This situation can be easily remedied by grounding the valve.



Bulk fuel-loading facilities, because of high fluid velocities, present a problem to both metallic and fiberglass pipe. Filters and other high surface area devices are prolific generators of static electricity at these facilities. Special grounding procedures may be necessary under these conditions.

F. STEAM CLEANING

Short duration steam cleaning of epoxy fiberglass pipe is acceptable provided the following recommendations are adhered to:

- The piping system must be open-ended to prevent pressure buildup.

- The maximum steam pressure does not exceed 15 psig corresponding to a steam saturation temperature of approximately 250°F. Contact a factory representative for specific product design information.
- The piping system design must consider the effects of the steam cleaning temperatures. In most cases the support spans will be reduced 15-35%.
- Contact the factory before steam cleaning vinyl ester or polyester pipe.

G. THRUST BLOCKS

Thrust blocks are not typically required for bonded piping systems capable of restraining thrust loads. FGS large diameter F-CHEM O-ring pipe is not restrained and may require the use of thrust blocks. Consult the factory for specific recommendations.

H. VACUUM SERVICE

Vacuum service may be a system design condition, or it may occur as the result of an inadvertent condition. Sudden pump shut off, valve closures, slug flow and system drain down are examples of flow conditions that result in vacuum. They should always be considered during the design phase. Regardless of the source, vacuum conditions result when the external atmospheric pressure exceeds the internal pressure. The pipe wall must be capable of resisting this external pressure without buckling. Fiber Glass Systems' product bulletins should be consulted for specific external pressure (vacuum) ratings. Large diameter pipe through 72-inches manufactured specifically for vacuum conditions are available upon request.

I. VALVES

When using valves with fiberglass piping products, consideration must be given to the corrosion resistance of the valve with respect to the fluid being conveyed and the external environment. Valves should be independently supported to reduce bending loads on the adjacent pipe. Flanged valves mated to molded fiberglass flanges must have a full flat face to prevent overstressing the flanges. To ensure a good seal, use a 1/8-inch thick full-face, 60-70-durometer gasket between the valve sealing surface and the fiberglass flange for up to 14-inch diameter pipe. Use 0-inch thick gaskets on larger sizes. If the valves do not have full flat faces consult installation manuals for additional recommendations.

J. VIBRATION

Low amplitude vibrations such as those produced by well-anchored centrifugal pumps will have little effect on Smith Fibercast piping. Such vibrations will be dampened and absorbed by the relatively low modulus pipe.

SECTION 5. OTHER CONSIDERATIONS

However, care must be taken to protect the exterior of the pipe from surfaces that might abrade and wear through the pipe wall over a long period of time. This can be accomplished by applying protective sleeves to the pipe at the first two or three supports or padding these supports with 1/8-inch rubber gasket material.

High amplitude vibration from pumps or other equipment must be isolated from the piping system by flexible connectors.

K. FLUID HAMMER

A moving column of fluid has momentum proportional to its mass and velocity. When flow is abruptly stopped, the fluid momentum is converted into an impulse or high-pressure surge. The higher the liquid velocity and longer the pipe line, the larger the impulse.

These impulse loads can be of sufficient magnitude to damage pipe, fittings and valves.



Accurate determination of impulse loads is very complex and typically requires computer modeling of the piping system. However, the Talbot equation, given in **Appendix A**, may be used to calculate theoretical impulses assuming an instantaneous change in velocity. Although, it is physically impossible to close a valve instantaneously, Talbot's equation is often employed to calculate worst case conditions.

In the real world quick reacting valves, reverse flow into check valves and sudden variations in pump flow rates will cause water hammer surges. Engineers typically incorporate slow operating valves, surge tanks and soft-starting pumps into piping systems to minimize fluid hammer. Piping systems that experience surge conditions should be restrained to prevent excessive movement.

If the system operating pressure plus the peak surge pressure exceeds the system pressure rating, then a higher pressure class piping system should be employed.

L. ULTRAVIOLET (U.V.) RADIATION AND WEATHERING

Fiberglass pipe undergoes changes in appearance when exposed to sunlight. This is a surface phenomenon caused by U.V. degradation of the resin. The degradation depends upon the accumulated exposure and the intensity of the sunlight. Long-term surface degradation may expose the outer layer of glass fibers; this condition is called "fiber-blooming". These exposed glass fibers will block and reflect a significant portion of ultraviolet radiation resulting in a slower rate of degradation. This minimizes future damage to the remaining pipe wall. Because Fiber Glass Systems pipe bodies are designed with significant safety factors, minor fiber blooming does not prevent the pipe from safely performing at its published pressure rating. If service conditions are such that

exposed fibers will be abraded with time, it is highly recommended that surface be protected. Painting the pipe with a good quality acrylic or solvent-based paint is useful in blocking UV radiation.

M. FUNGAL, BACTERIAL, AND RODENT RESISTANCE

Some plastics (thermoplastics) are subject to fungal, bacterial, and/or rodent attack, but fiberglass pipe offers no nourishment or attraction to these annoyances. Under stagnant conditions, some marine growths will attach to fiberglass surfaces, but they do not attack or bore into the pipe and are usually easily removed. **Note regarding zebra mussels:** It was recently reported that a utility compared zebra mussel growth in similar metal and fiberglass intake lines at the same location. Only two liters of zebra mussels were removed from the fiberglass line, while two dumpster loads of mussels were removed from a metal line.

N. FLANGE CONNECTIONS

Smith Fibercast flanges are designed to meet ANSI B16.5 Class 150 bolt hole standards. Alternate bolt hole standards are available. Smith Fibercast flanges are designed for 1/8 inch thick gaskets made from materials with a 60-70 durometer Shore A hardness. The use of flat washers under nuts and bolt heads is required. Refer to the appropriate product specific fittings bulletin for recommended bolt torque values.

Raised Face Flange Connections

Special mating requirements exist when connecting flat-face compression molded fiberglass flanges to raised-face metallic flanges or valves having partial liner facings. The addition of a metallic spacer ring placed between the raised face and the outer edge of the flange to form a full flat-face on the mating flange is recommended. The purpose of the spacer ring is to fill the gap outside the raised-face to prevent bolt loads from bending and breaking the fiberglass flange. An alternative to the spacer ring is the use of metallic back-up rings behind molded fiberglass flanges. Filament wound flanges may be connected directly to raised-face flanges without the use of spacer rings.

Lug and Wafer Valves

Lined lug and wafer valves that use integral seals, use a 1/4" steel spacer plate with an inner diameter equal to Schedule 40 steel or as required by the valve manufacturer. The spacer plate outer diameter should match the fiberglass flange outer diameter.

Unlined lug and wafer valves without integral seals may be directly connected to fiberglass filament flanges without back up rings or to molded flanges with metal back-up rings.

SECTION 6. SPECIFICATIONS and APPROVALS

SECTION 6. Specifications and Approvals

A. COMPLIANCE WITH NATIONAL SPECIFICATIONS

American Petroleum Institute

API Specification 15LR

RED THREAD II Pipe & Fittings, 8"-16" Cyclic Design

American Society for Testing & Materials (ASTM)

ASTM D2310 (See Table 6.0 & 6.2)

"Standard Classification for Machine Made 'Fiberglass' (Glass-Fiber-Reinforced Thermosetting-Resin) Pipe" Classifications of Pipe at 73.4°F are:

ASTM D4024 (See Table 6.1)

"Standard Specification for Machine Made 'Fiberglass' (Glass-Fiber-Reinforced Thermosetting-Resin) Flanges"

Designation Codes at 73.4°F, by flange size, are available in product bulletins.

B. APPROVALS, LISTINGS, AND COMPLIANCE WITH REGULATIONS

American Water Works Association

RED THREAD II pipe, GREEN THREAD pipe, and F-CHEM pipe can be made in compliance with AWWA M45 for use as pressure pipes for water distribution (including services) and transmission systems for both above and below ground installations. When ordering, specify AWWA M45.

ASME/ANSI B31.3

"Chemical Plant and Petroleum Refinery Pipe Code" RED THREAD II and GREEN THREAD pipe that are manufactured in compliance with ASTM D2996, and CENTRICAST pipe manufactured in compliance with D2997, can be installed in compliance with ASME/ANSI B31.3.

Factory Mutual

Pipe and fittings, sizes 4"-16", are available with Factory Mutual approval for underground fire protection piping systems; pressure ratings to 200 psig. *When ordering, specify Factory Mutual Products.*

Food and Drug Administration

The resins and curing agents used in the manufacture of RED THREAD II Pipe and Fittings and GREEN THREAD Pipe and Fittings are defined as acceptable with the U.S. Food, Drug, and Cosmetic Act as listed under 21 CFR Part 177 Subpart C Section 177.2280 and 21 CFR Part 175 Subpart C Section 175.300.

Military Specifications

MIL-P-29206 or MIL-P-29206A—RED THREAD II JP and GREEN THREAD JP pipe and fittings, sizes 2"-12", are certified to be in compliance with MIL-P-29206 or MIL-P-29206A, Military Specification: "Pipe and Pipe Fittings, Glass Fiber Reinforced Plastic for Liquid Petroleum Lines."

TABLE 6.0 ASTM D2310 Classification

Pipe	Size	ASTM D2310 Classification
RED THREAD II	2"-3" 4"-24"	RTRP-11AF RTRP-A11AH
GREEN THREAD	1"-16"	RTRP-11FF
Z-CORE	1"-8"	RTRP-21CO
SILVER STREAK	2"-48"	RTRP-11FF
CERAM CORE	6"-16"	RTRP-11CF
F-CHEM	1"-72"	RTRT-12EU
CENTRICAST: RB-1520 RB-2530 CL-1520 CL-2030	1½"-14" 1"-14" 1½"-14" 1"-14"	RTRP-21CW RTRP-21CW RTRP-22BT RTRP-22BS

* Static HDB

ASTM D2996

"Standard Specification for Filament-Wound 'Fiberglass' (Glass-Fiber-Reinforced Thermosetting-Resin) Pipe" Designation Codes are available in product bulletins.

ASTM D2997

"Standard Specification for Centrifugally Cast 'Fiberglass' (Glass-Fiber-Reinforced Thermosetting-Resin) Pipe" Designation Codes are available in product bulletins.

SECTION 6. SPECIFICATIONS and APPROVALS

NSF International

(National Sanitation Foundation)

ANSI/NSF Standard No. 14 (Plastic Piping Components and Related Materials) Listing for conveying potable water:

2"-24" RED THREAD II Pipe & Fittings (Performance Standard ASTM D2996, RTRP-11AF).

1"-24" GREEN THREAD Pipe & Fittings (Performance Standard ASTM D2996, RTRP-11FF).

ANSI/NSF Standard No. 61 (Drinking Water System Components—Health Effects) Listing: Note: Standard No. 61 was developed by a consortium and with support from the U.S. Environmental Protection Agency under cooperative agreement No. CR-812144:

RED THREAD II Pipe

GREEN THREAD Pipe

RED THREAD II Fittings

GREEN THREAD Fittings

8000 Series (Epoxy Adhesive)

F-CHEM Pipe (1)

F-CHEM Fittings(1)

When ordering, specify NSF.

- (1) Piping greater than 14" diameter using NSF Listed resin system.

Underwriters Laboratories Inc. (UL) and Underwriters' Laboratories of Canada (ULC)

RED THREAD II pipe and compatible primary fittings, along with secondary containment pipe and fittings, and adhesives are listed for use in conveying petroleum products, alcohols, and alcohol-gasoline mixtures including ethanol, methanol and MTBE underground (UL). The primary pipe sizes are 2", 3" and 4"; the secondary containment pipe and fittings sizes are 3" and 4".

These products are listed for use in conveying petroleum products, gasoline mixtures and up to 100% ethanol underground (ULC).

TABLE 6.1 Table for Use in Classifying Fiberglass Flanges to ASTM D4024

	Type	Grade	Class	Pressure Rating Designation*	Property Designation				
Filament Wound (FW)	1								
Compression Molded.....	2								
Resin-Transfer Molded.....	3								
Centrifugally Cast.....	4								
Epoxy Resin		1							
Polyester Resin		2							
Furan Resin.....		3							
Integrally-Molded (mfg. on pipe/fitting)			1						
Taper to Taper Adhesive Joint			2						
Straight to Taper Adhesive Joint			3						
Straight Adhesive Joint.....			4						
*Gauge Pressure (psig)		50		A					
(Flanges must withstand a pressure		100		B					
of 4 times the rating without damage		150		C					
to the flange)		200		D					
		250		E					
		300		F					
		400		G					
		500		H					
PROPERTY	0	1	2	3	4	5	6	7	8
Burst Pressure (psig)	(unspecified)	200	400	600	800	1000	1200	1600	2000
Sealing Test Pressure (psig)		75	150	225	300	375	450	600	750
Bolt Torque Limit (ft.·lbs.)		20	30	50	75	100	125	150	200

SECTION 6. SPECIFICATIONS and APPROVALS

TABLE 6.2 Classifying Fiberglass Pipe				ASTM D2310				ASTM D2996				ASTM D2997				
Type	Grade	Class	Hoop Stress HDB D2992	Test-End Closures D2992	Short Term Burst D1599	Longit. Tensile Strength D2105	Tensile Modulus x 10 ⁶ D2105	Stiffness Factor @ 5% Defl D2412	Short Term Burst D1599	Longit. Tensile Strength D2105	Tensile Modulus x 10 ⁶ D2105	Stiffness Factor @ 5% Defl D2412	Short Term Burst D1599	Longit. Tensile Strength D2105	Tensile Modulus x 10 ⁶ D2105	Stiffness Factor @ 5% Defl D2412
Filament Wound (FW).....1 Centrifugally Cast (CC).....2																
Glass Fiber Reinforced Epoxy Resin.....1 Glass Fiber Reinforced Polyester Resin.....2 Glass Fiber Reinforced Phenolic Resin.....3 Glass Fiber Reinforced Furan Resin.....7																
No Liner.....A Polyester Resin Liner (Non-Reinforced).....B Epoxy Resin Liner (Non-Reinforced).....C Phenolic Resin Liner (Non-Reinforced).....D Polyester Resin Liner (Reinforced).....E Epoxy Resin Liner (Reinforced).....F Phenolic Resin Liner (Reinforced).....G Thermoplastic Resin Liner (Specify).....H Furan Resin Liner (Reinforced).....I																
Cyclic Values (Determined by D2992 Procedure A)			2500.....A 3150.....B 4000.....C 5000.....D 6300.....E 8000.....F 10000.....G 12500.....H													
Static Values (Determined by D2992 Procedure B)			5000.....Q 6300.....R 8000.....S 10000.....T 12500.....U 16000.....W 20000.....X 25000.....Y 31500.....Z													
Free End.....1 Restrained End.....2																
Number in Last Four Positions.....0123456			(Unspecified) 10000 30000 40000 50000 60000 70000													
Examples: 2"-8" GREEN THREAD Pipe RTRP 11FF1-3112 FW Epoxy Epoxy-Re 8000 Free End 40000 10300 1.8 200 10"-12" CL-2030 RTRP-22BS-4444 CC Polyester Poly-Re 8000 30000 22000 2.1 73																

APPENDICES

APPENDIX A

USEFUL FORMULAS

Where: A = Area; A1 = Surface area of solids; V = Volume; C = Circumference

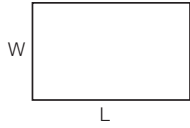

Rectangle
A = W · L

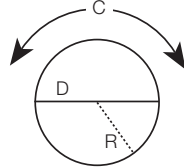

Circle
A = π · R²
C = π · D
R = D / 2
D = 2 · R

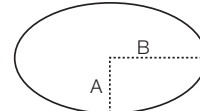

Ellipse
A = π · A · B
C = 2π · √((A + B) / 2)

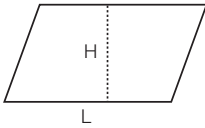

Parallelogram
A = H · L

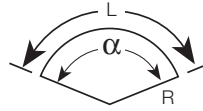

Sector of Circle
A = (π · R² · α) / 360
L = (π / 180) · R · α
α = (180L) / (π · R)
R = (180 · L) / (π · α)

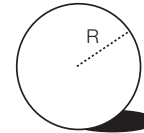

Sphere
A = 4 · π · R²
V = (4 / 3) · π · R³

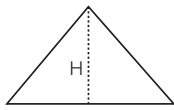

Triangle
A = (1 / 2) · W · H

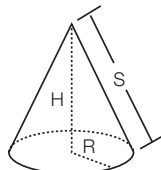

Cone
A = π · R · (S + R)
V = (π / 180) · R² · H

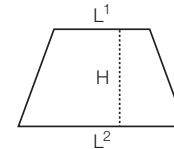

Trapezoid
A = H · (L₁ + L₂) / 2

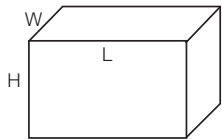

Rectangular Solid
A = 2 (W · L + L · H + H · W)
V = W · L · H

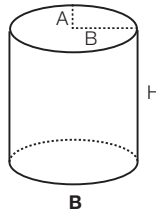

Elliptical Tanks
area = 2 · π · (A · B + √((A² + B²) / 2) · H)
V = π · A · B · H

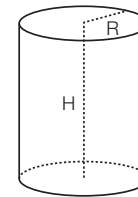

Cylinder
A = 2 · π · R · (H + R)
V = π · H · R²

For Above Containers:

Capacity in gallons = $\frac{V}{231}$ when V is in cubic inches Capacity in gallons = 7.48 x V when V is in cubic feet

SUPPORT SPANS

“Three Moment Equation” for a uniformly loaded continuous beam.

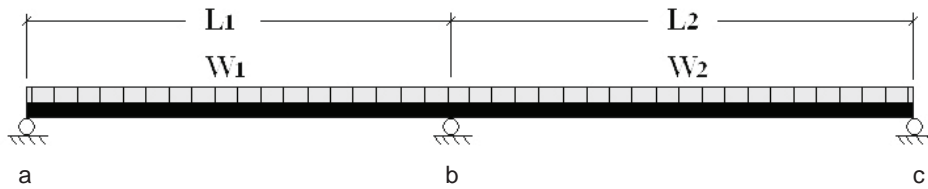

$$\frac{M_a \cdot L_1}{I_1} + 2 \cdot M_b \cdot \left(\frac{L_1}{I_1} + \frac{L_2}{I_2} \right) + \frac{M_c \cdot L_2}{I_2} + \frac{W_1 \cdot \{L_1\}^3}{4I_1} + \frac{W_2 \cdot \{L_2\}^3}{4I_2} = 0$$

Where:

- Ma = Internal moment at support A, in-lb(N-m)
- Mb = Internal moment at support B, in-lb(N-m)
- Mc = Internal moment at support C, in-lb(N-m)
- L₁ = Span length between A & B, in(m)
- L₂ = Span length between B & C, in(m)
- I₁ = Area moment of inertia of span 1, in⁴(m⁴)
- I₂ = Area moment of inertia of span 2, in⁴(m⁴)
- W₁ = Uniformly distributed load on span 1, lb/in(N/m)
- W₂ = Uniformly distributed load on span 2, lb/in(N/m)
- E = Pipe beam bending modulus of elasticity, lb/in²(N/m²)

WATER HAMMER

$$P := \rho \cdot \left[E_v \cdot t \cdot \frac{E}{\rho \cdot (t \cdot E + D \cdot E_v)} \right]^{0.5} \cdot \delta V$$

Talbot Equation for calculating the surge pressure due to an instantaneous change in flow velocity.

Where:

- P = Pressure surge, lb/in² (N/m²)
- ρ = Mass density, lb/in³ (kg/m³)
- E_v = Volume modulus compressibility of fluid, lb/in² (N/m²)
- E = Hoop modulus of elasticity of pipe wall, lb/in² (N/m²)
- t = Pipe wall thickness, in (m)
- D = Pipe inner diameter, in (m)
- δV = Change in velocity, ft/sec (m/sec)

GEOMETRIC RELATIONSHIPS FOR MINIMUM BENDING RADIUS

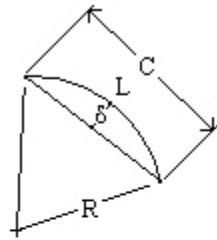

$$\delta = R \cdot \left(1 - \cos\left(\frac{L}{2 \cdot R}\right) \right)$$

$$C = 2 \cdot R \cdot \sin\left(\frac{L}{2 \cdot R}\right)$$

Where:

L = pipe length, ft(m)

R = minimum bend radius, ft(m)

δ = maximum offset deflection, ft(m)

C = chord length, ft(m)

(trigonometric functions based on radians)

MINIMUM BENDING RADIUS LAYOUT

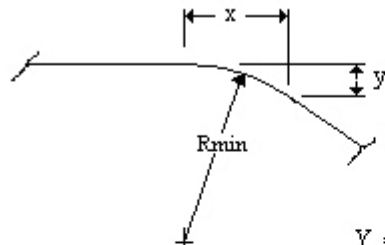

$$Y = R \cdot \left(1 - \cos\left(\text{asin}\left(\frac{X}{R}\right)\right) \right)$$

Where:

X = Run, ft(m)

Y = Offset, ft(m)

R = minimum bend radius, ft(m)

(trigonometric function based on radians)

Table A.1 Water Pressure to Feet of Head

Pounds Per Square Inch	Feet Head	Pounds Per Square Inch	Feet Head
1	2.31	100	230.90
2	4.62	110	253.98
3	6.93	120	277.07
4	9.24	130	300.16
5	11.54	140	323.25
6	13.85	150	346.34
7	16.16	160	369.43
8	18.47	170	392.52
9	20.78	180	415.61
10	23.09	200	461.78
15	34.63	250	577.24
20	46.18	300	692.69
25	57.72	350	808.13
30	69.27	400	922.58
40	92.36	500	1154.48
50	115.45	600	1385.39
60	138.54	700	1616.30
70	161.63	800	1847.20
80	184.72	900	2078.10
90	207.81	1000	2309.00

Note: One pound of pressure per square inch of water equals 2.309 feet of water at 62° Fahrenheit. Therefore, to find the feet head of water for any pressure not given in the table above, multiply the pressure pounds per square inch by 2.309.

Table A.2 Feet of Head of Water to psi

Pounds Per Square Inch	Feet Head	Pounds Per Square Inch	Feet Head
1	.43	100	43.31
2	.87	110	47.64
3	1.30	120	51.97
4	1.73	130	56.30
5	2.17	140	60.63
6	2.60	150	64.96
7	3.03	160	69.29
8	3.46	170	73.63
9	3.90	180	77.96
10	4.33	200	86.62
15	6.50	250	108.27
20	8.66	300	129.93
25	10.83	350	151.58
30	12.99	400	173.24
40	17.32	500	216.55
50	21.65	600	259.85
60	25.99	700	303.16
70	30.32	800	346.47
80	34.65	900	389.78
90	38.98	1000	433.00

Note: One foot of water at 62° Fahrenheit equals .433 pound pressure per square inch. To find the pressure per square inch for any feet head not given in the table above, multiply the feet head by .433.

Table A.3 Dry Saturated Steam Pressure

ABS Press., Lbs./Sq. In.	Temp °F	ABS Press., Lbs./Sq. In.	Temp °F
0.491	79.03	30	250.33
0.736	91.72	35	259.28
0.982	101.14	40	267.25
1.227	108.71	45	274.44
1.473	115.06	50	281.01
1.964	125.43	55	287.07
2.455	133.76	60	292.71
5	162.24	65	297.97
10	193.21	70	302.92
14.696	212.00	75	307.60
15	213.03	80	312.03
16	216.32	85	316.25
18	222.41	90	320.27
20	227.96	100	327.81
25	240.07	110	334.77

Table A.4 Specific Gravity of Gases (At 60°F and 29.92 Hg)

Dry Air (1cu. ft. at 60° F. and 29.92" Hg. weighs .07638 pound)	1.000
Acetylene C2H2	0.91
Ethane C2H6	1.05
Methane..... CH4	0.554
Ammonia NH3	0.596
Carbon-dioxide CO2	1.53
Carbon-monoxide CO	0.967
Butane C4H10	2.067
Butene C4H8	1.93
Chlorine Cl2	2.486
Helium He	0.138
Hydrogen H2	0.0696
Nitrogen..... N2	0.9718
Oxygen O2	1.1053

Table A.5 Specific Gravity of Liquids

Liquid	Temp ° F	Specific Gravity
Water (1cu. ft. weighs 62.41 lb.)	50	1.00
Brine (Sodium Chloride 25%)	32	1.20
Pennsylvania Crude Oil	80	0.85
Fuel Oil No. 1 and 2	85	0.95
Gasoline	80	0.74
Kerosene	85	0.82
Lubricating Oil SAE 10-20-30	115	0.94

Table A.6 Weight of Water

1 cu. ft. at 50° F	weighs 62.41 lb.
1 gal. at 50° F	weighs 8.34 lb.
1 cu. ft. of ice	weighs 57.2 lb.
1 cu. ft. at 39.2° F	weighs 62.43 lb.

Water is at its greatest density at 39.2° F

APPENDICES

Table A.7 Conversion Factors

Pressure

1 in. of mercury	= 345.34 kilograms per sq. meter = 0.0345 kilograms per sq. centimeter = 0.0334 bar
1 lb. per sq. in.	= 0.491 lb. per sq. in. = 2.036 in. head of mercury = 2.309 ft. head of water = 0.0703 kilogram per sq. centimeter = 0.0690 bar = 6894.76 pascals
1 pascal	= 1.0 newton per sq. meter = 9.8692 x 10 ⁻⁶ atmospheres = 1.4504 x 10 ⁻⁴ lbs. per sq. in. = 4.0148 x 10 ⁻³ in. head of water = 7.5001 x 10 ⁻⁴ cm. head of mercury = 1.0200 x 10 ⁻⁵ kilogram per sq. meter = 1.0 x 10 ⁻⁵ bar
1 atmosphere	= 101,325 pascals = 1,013 milibars = 14.696 lbs. per sq. in.

Temperature

° C.	= (° F.-32) x 5/9
Weight of Liquid	
1 gal. (U.S.)	= 8.34 lb. x sp. gr.
1 cu. ft.	= 62.4 lb. x sp. gr.
1 lb.	= 0.12 U.S. gal. ÷ sp. gr. = 0.016 cu. ft. ÷ sp. gr.

Flow

1 gpm	= 0.134 cu. ft. per min. = 500 lb. per hr. x sp. gr.
500 lb. per hr.	= 1 gpm ÷ sp. gr.
1 cu. ft. per min.(cfm)	= 448.8 gal. per hr. (gph)

Work

1 Btu (mean)	= 778 ft. lb. = 0.293 watt hr. = 1/180 of heat required to change temp of 1 lb. water from 32° F. to 212° F.
1 hp-hr	= 2545 Btu (mean) = 0.746 kw hr
1 kw hr	= 3413 Btu (mean) = 1.34 hp-hr.

Power

1 Btu per hr.	= 0.293 watt = 12.96 ft. lb. per min. = 0.00039 hp
1 ton refrigeration (U.S.)	= 288,000 Btu per 24 hr. = 12,000 Btu per hr. = 200 Btu per min. = 83.33 lb. ice melted per hr. from and at 32° F. = 2000 lb. ice melted per 24 hr. from and at 32° F.
1 hp	= 550 ft. lb. per sec. = 746 watt = 2545 Btu per hr.
1 boiler hp	= 33,480 Btu per hr. = 34.5 lb. water evap. per hr. from and at 212° F. = 9.8 kw.
1 kw.	= 3413 Btu per hr.

Mass

1 lb. (avoir.)	= 16 oz. (avoir.) = 7000 grain
1 ton (short)	= 2000 lb.
1 ton (long)	= 2240 lb.

Volume

1 gal. (U.S.)	= 128 fl. oz. (U.S.) = 231 cu. in. = 0.833 gal. (Brit.)
1 cu. ft.	= 7.48 gal. (U.S.)

 Fiber Glass Systems™



2700 West 65th Street • Little Rock, AR 72209
(501) 568-4010 • Fax: (501) 568-4465

P.O. Box 968 • 25 South Main • Sand Springs, OK 74063
(918) 245-6651 • Fax: (918) 245-7566 or Fax: (800) 365-7473

<http://www.smithfibercast.com>